

ATS-22

Ver1.0

AUTOMATIC TRANSFER SWITCH CONTROL UNIT OPERATOR'S MANUAL



A complete Automatic-transfer-switch PLC controller. It works with most ATS and incorporates all power relays and connections together with the software for each type of ATS. It also has a slot to accommodate a USB, RS485 or Ethernet communications module. Easy to install, easy to program.

TABLE OF CONTENTS

Section	Page
SECTION 1 : INTRODUCTION	
1.1 Safety Precautions	3
1.2 Preliminary Comments.....	3
1.3 Product Overview.....	3
1.4 Functions / Features	3
SECTION 2 : OPERATION PANEL	
2.1 General.....	5
2.2 Display Window.....	5
2.3 Operate Touch Buttons.....	5
2.4 Panel LED Outputs	6
SECTION 3 : OPERATION	
3.1 General.....	7
3.2 AUTO Mode	7
3.3 OFF Mode	7
3.4 Manual Test Mode (TEST).....	7
3.5 Programming Instruction.....	7
3.6 Remote Communication Instruction.....	8
3.7 Line by Line Programming Table.....	10, 11
3.10 Specification Summary	12
SECTION 4 : INSTALLATION INSTRUCTIONS	
4.1 General.....	12
4.2 Panel Cut-Out	12
4.3 Unit Dimensions	13
4.4 Installation Reference	13
SECTION 5 : TYPICAL WIRING	
NOTES Voltage Adjustment	END
NOTE Touch Buttons Sensitivity Adjustment.....	END

SECTION 1 : INTRODUCTION

1.1 Safety Precautions

The manual covers installation, operation and maintenance of the ATS-22 Automatic Transfer Switch PLC Controller. This manual is for use by authorized and qualified personnel only.

<p>WARNING High voltage can kill.</p>

1.2 Overview

Transfer switches protect important electrical loads against loss of power. A standby (emergency) generator backs up the normal grid power. The transfer switch connects either the normal or the emergency supply to the load. When power is lost from the grid, the transfer switch transfers the load to the standby source. Eventually after the grid is restoration, the ATS connects the load back to the grid.

1.3 Product Overview

The ATS-22 is a multifunction programmable logic automatic transfer switch Controller. Suitable for single and 3 phase system, including all necessary monitoring and protections. It works with most transfer switch in the marketplace.

- Microchip based with a full-glass panel design.
- Smart touch screen (touch sensor) design.
- Compact size with user-friendly LED display
- Programmable for either cycle or fix displays & for 3 and 1-phase voltages and frequency.
- Direct programming and operation using simple touch screen interface.
- Monitors the grid and the generator for over and under voltage anomalies
- Monitors grid and emergency for over and under frequency anomalies
- Optional exercise with or without load
- Optional 1 week to 4 weeks automatic scheduled exercise / testing
- Pre-alert warning signal output for transferring operation
- Transfer failure output signal

- Pre-alert warning signal output for scheduled automatic Exercise / testing
- Compatible with all ATS switches (worldwide)
- Optional USB / RS485 / Ethernet remote (mobile proxy) communication functions.
- Can be programmed on-site or from remote (mobile) device (PC, Smart Phone).
- Auto-saved settings (memory safe from lost of power and resets)
- Front panel display provides source status and fail alarm indications.

1.4 Functions / Features

The primary function of ATS-22 controller is to monitor grid/normal street power and to provide the necessary intelligence to operate a seamless automatic transfer of load.

1.4.1 Operational Simplicity

The design of the ATS-22 controller panel interface simplifies routine operation, and programming.

1.4.2 Standard Features

Control settings for different ATS are stored in the (NVRAM), when power is off. The user adjusts some feature and set points.

Time Delay Emergency to Normal (TDEN)

TDEN delays the transfer from the emergency source to the normal Source to permit stabilization of the normal source before retransfer is made. Timing begins when the normal source becomes available

(Refer to program table line 3)

Adjustable TDEN time range: 0.0 to 250 sec

Time Delay Normal to Emergency (TDNE)

TDNE delays the transfer from normal to emergency to permit stabilization of the generator before it takes up the load. Timing begins when the emergency becomes available

(Refer to program table line 4)

Adjustable TDEN time range: 0.0 to 250 sec

**ATS-22 AUTOMATIC TRANSFER SWITCH
CONTROL UNIT**

Time Delay Engine Start (TDES)

The TDES Time (Delays Engine Start) this timer prevents nuisance start because of momentary electrical glitches. If power normalizes before the countdown ends, the controller skips the engine start and resets the timer

(Refer to program table line 5)

Adjustable TDES time range: 0 to 30 sec

Time Delay Engine Cool-down (TDEC)

TDEC permits the generator to run unloaded after the ATS retransfer back the load to the grid. Timing begins when the ATS connects back to grid power.

(Refer to program table line 6)

TDEC range: 0 to 250 sec

Time Delay Center OFF Position

This timer temporarily stops the switch in the center OFF position (completely cut off) before proceeding to normal.

(Refer to program table line 7)

Adjustable time delay range: 0 to 99 sec

Full Phase Over/Under Voltage and Loss of Phase Sensing

The controller monitors full phase output voltage from grid and emergency power. The client can program over & under voltage window.

(Refer to program table line 8, 9, 10, 14, 15 & 16)

O/V adjustment range: 110VAC to 500VAC

O/V reset value: -10VAC (Not adjustable)

U/V adjustment range: 80VAC to 470VAC

U/V reset value: +10VAC (Not adjustable)

Under / Over Frequency Sensing

The controller monitors grid and generator frequency. The client can set the over & under frequency range

(Refer to program table line 11, 12, 13, 17, 18 & 19)

O/F adjustable range: 51Hz to 75Hz

O/F reset value: -1 Hz (Not adjustable)

U/F adjustable range: 40Hz to 59Hz

U/F reset value: -1 Hz (Not adjustable)

Programmable exerciser

It can be set to exercise one time per week to one time every 4 weeks on any day and time, with or without load. The length of the exercise is also set.

(Refer to program table line 23, 24, 25, 26 & 27)

Failure Warning Output

The controller also has one dry contact that can be set to react to one of three-failure warning

(Refer to program table line 30)

- Transfer failure warning
- Pre-transfer warning
- Pre-test / exercise warning

NOTICE
ATS-22 provides one auxiliary contact for external output signal for Transfer Failure, Pre-transfer or Pre-exerciser alarm output

Controller Panel Lighting Test

This checks the LED lights. Press the OFF button twice, all panel LEDs must light up.



**ATS-22 AUTOMATIC TRANSFER SWITCH
CONTROL UNIT**

SECTION 2 : OPERATION PANEL

2.1 General

Get acquainted with the ATS-22:

- The Front Display Window
- The Touch Buttons
- Panel LEDs Display

2.2 Display Window

The ATS-22 uses a four-digit, seven-segment display to screen all parameters, setting and messages.

The screen display's

- Full phase voltage / frequency display
- Current Time HH:MM (In OFF only)
- Delay countdown display
- Program parameter display



2.3 Operate Touch Buttons

The front panel employs five sensitive capacitive touch and release buttons.



2.3.1 Increase (▲) Button

In AUTO, each touch of the up arrow (▲) changes the display to the next phase voltage.

However, when programming every touch of the up (▲) button increases the displayed parameter by a single unit. If held, the up (▲) button continues to scroll.

2.3.2 Decrease (▼) Button

In AUTO, each touch of the down (▼) button changes the display between voltage, duty time and frequency.

However, when programming every touch of the down (▼) button decreases the displayed parameter by a single unit. If held, the down (▼) button continues to scroll

2.3.3 Auto Button

In AUTO, the ATS-22 runs in automatic, lighting the corresponding LED to indicate that its in AUTO. The controller automatically transfers and retransfers from grid to emergency generator power as needed by the settings previously set.

2.3.4 Test Button

Pressing the TEST button simulates a power failure In TEST the generator starts and begins a preprogrammed execution and testing sequence made with or without loading the generator.

(Refer to program line 28)

2.3.5 OFF Button

Touching the OFF again, turns the ATS-22 OFF engaging a flashing red LED instantly disabling all functions and the screen shows the current time.



**ATS-22 AUTOMATIC TRANSFER SWITCH
CONTROL UNIT**

2.4 Panel LED Outputs

Eight individual red and blue LEDs light bars perform or indicating each function.

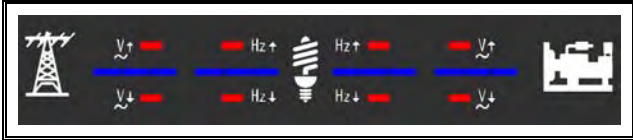

Information concerning the LEDs output

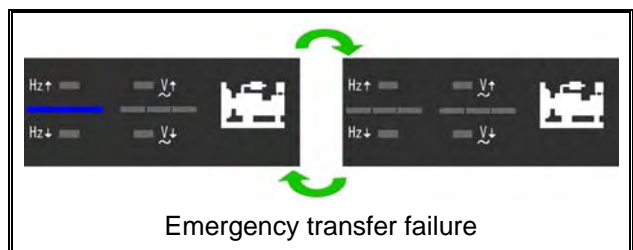
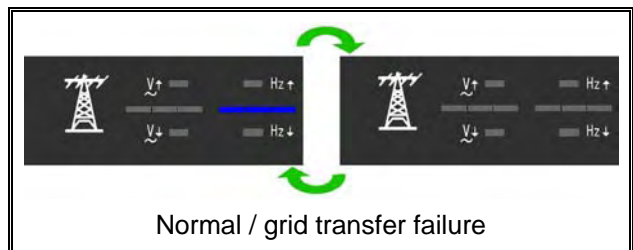
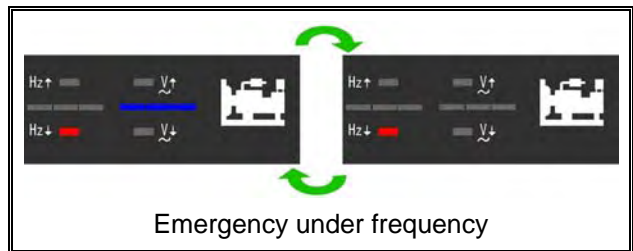
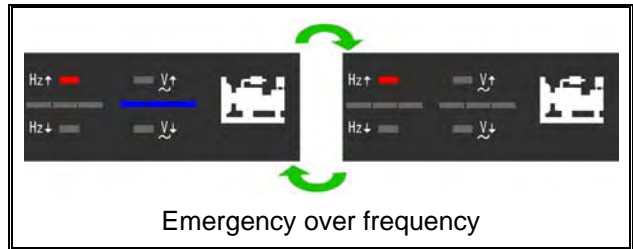
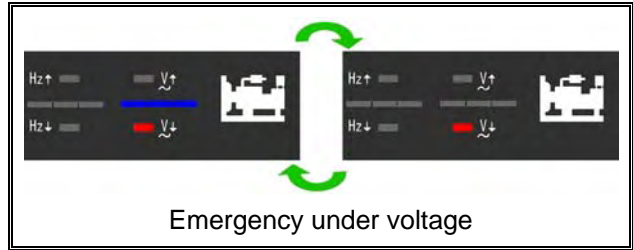
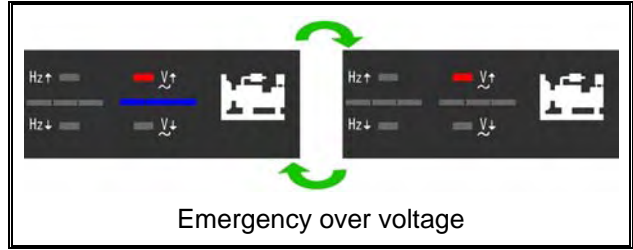
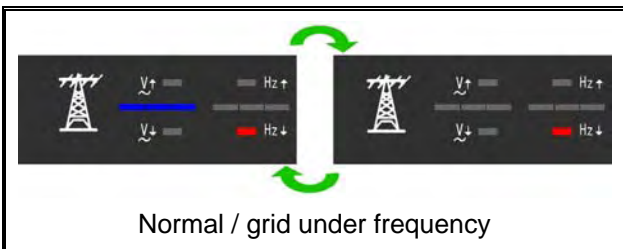
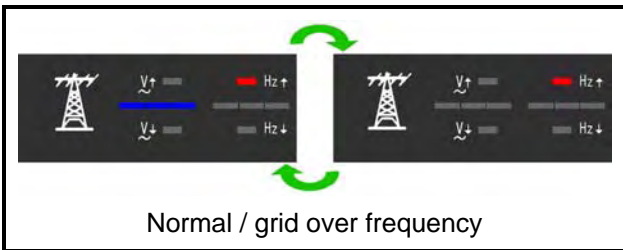
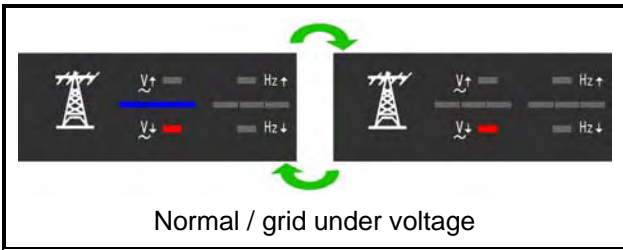
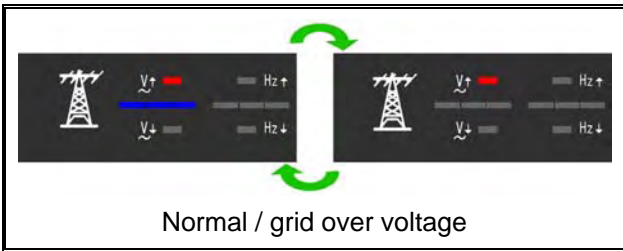
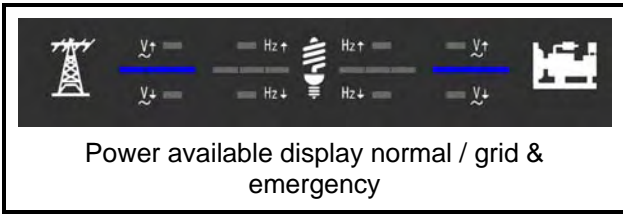

SECTION 3: OPERATION

3.1 General

The five functions of the ATS-22:

- Automatic mode
- OFF mode
- TEST mode
- Programming mode
- KCU-XX Remote Communication

3.2 (In Automatic) AUTO

The AUTO mode of the ATS-22 controller provides automatic engine start, stop, and power transfer and retransfers from source to source as dictated by the values previously programmed.

The ATS-22 constantly monitors the condition of both the grid and generators providing the intelligence for transfer operations.

3.3 (OFF) OFF Mode

In OFF the ATS-22 disables all the transfers and protection functions with all LED indicators off leaving the display screen only showing the time. User can test the LEDs by pressing the OFF button twice. Check and reset the clock every year. The wrong time can affect the schedule exerciser. Without power, the controller can maintain the clock working for up to a week.

However, when programming, the OFF button allows you to move to the next program line and then change the values for that line using down (▼) and up (▲) buttons.

3.4 (TEST) Manual TEST

Pressing TEST simulate a loss of normal/grid power. Permitting the controller to start the engine and carry out a power transfer. You can do this TEST with or without load.

To end, press the AUTO button. If normal power is available, the controller transfer back to normal and the engine follow the program shutdown procedure to stop the generator. However, by pressing the OFF button, the transfer switch remains in its current position stopping the engine, and bypassing

all time delays.

3.5 Programming Instruction

You program the ATS-22 from the front faceplate.

To start, set the controller to OFF and press & hold the OFF button for 4 seconds. The word "Vr1.0" appears on the display for 2 seconds, showing the software version.

You are now ready to start the line-by-line programming sequence. Always press the OFF key to move to the next line. To change the parameter, one each line use the up (▲) and down (▼) arrows. Repeatedly pressing the up (▲) or down (▼) key, changes the displayed by one. To change faster, hold the buttons down.

Remember to always press the "OFF" button to move to the next line or until the "End" appears on the screen. To end and exit at any time, hold the "OFF" key down for 4 seconds.

If you make an error or need to return to factory settings, stay or reenter programming and then hold the AUTO keys down for 4 seconds, until the word "Au.Po" appears on the screen verifying that all programming lines are factory reset back like in the manual..

(See line-by-line programming table for ATS-22 factory settings).

**ATS-22 AUTOMATIC TRANSFER SWITCH
CONTROL UNIT**

3.6 Remote Communication Instruction

You can control and monitor the ATS-22 from a PC by using the optional USB / RS485 or Ethernet communication modules, available from your distributor.

WARNING

A remote start signal can activate the ATS-22 and the engines can start at anytime without warning. Place a "Danger" warning sign next to the generator, stating that this generator can start at anytime!" also install a warning buzzer or a flash light. Unexpected engine starts can result in serious injury or death. When performing service or maintenance, always disconnect the remote start signal input.

If you have an Ethernet module installed on your ATS-22 you can remotely monitor and operate the ATS and generator using the iPhone and Android mobile phones. You can download the free Apps from the App Store or Google Play by keying "Kutai" and hit search.

You have the option of using one of these communications modules

KCU-01 – USB communication

KCU-02 – RS-485 communications

KCU-03 – Ethernet communications

If you have the ATS-22 working with a KCU module, you must program lines (32), (33) and (34). Line (32) is particularly important. Setting line (32) to "00", restricts you to READ ONLY and remote start control is disabled. (See Warning)

When using the KCU-02 the RS485 communication module set lines (33) and (34).

WARNING

ATS-22 with KCU-02 module constitutes a closed LAN network. Each controller address can be set from 1 to 99 and not to be repeated. Same transmission rate is a must !!

For more detail, information refers to the KCU-XX manual.

The installation for the KCU-XX communication module on the ATS-22 controller is easy.

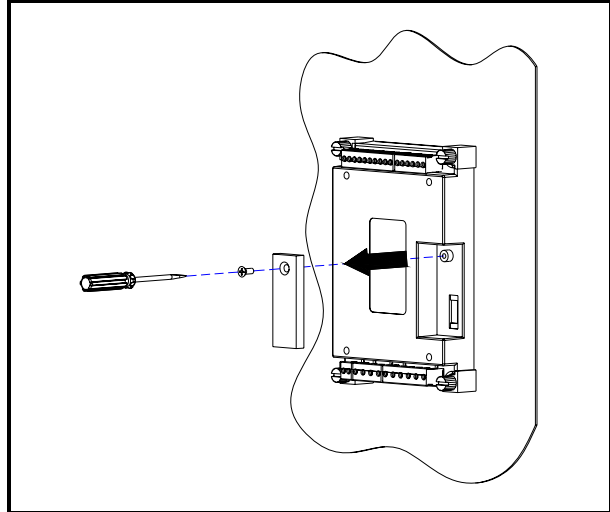

Step 2: Plug in tighten the screw on the KCU-XX module to the ATS-22 PCB.

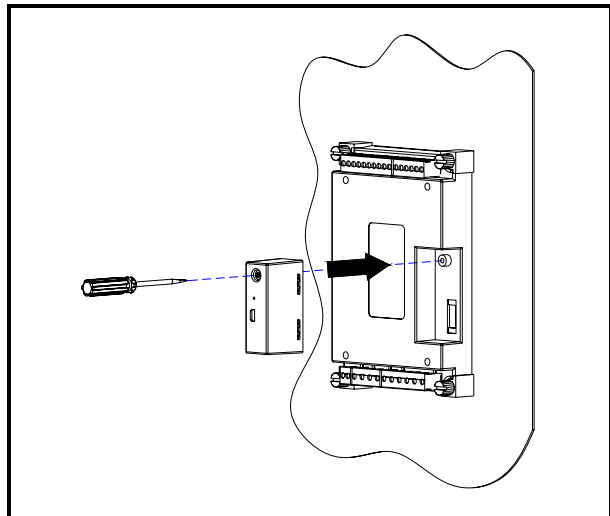

ATS-22 AUTOMATIC TRANSFER SWITCH
CONTROL UNIT

ATS-22
REMOTE COMMUNICATION ASSEMBLY

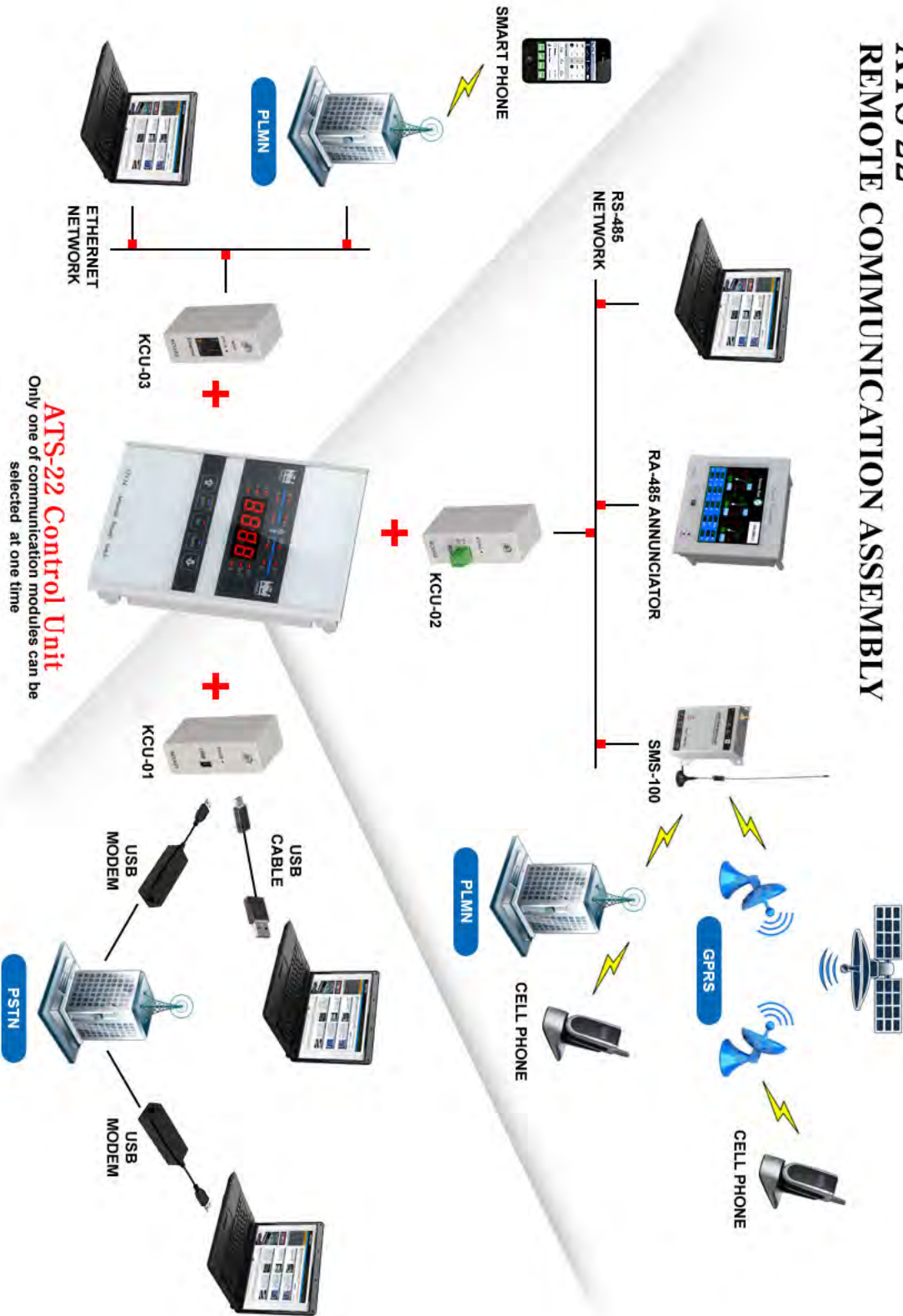

**ATS-22 AUTOMATIC TRANSFER SWITCH
CONTROL UNIT**

3.7 Line by Line Programming Table

LINE	DESCRIPTION	VALUE	FACTORY SETTING
1	Is the ATS operator in single or 3 phase	00 → Single 01 → 3 Phase	01
2	Select Switch ATS type See drawings on the back of this manual for guidance on different ATS types	00) MCCB BTS type ATS (Single motor) 01) Mot type ATS (MCCB with motors) 02) Air circuit breaker (ACB) 03) Double throw type (Single coil) 04) Double throw type (Dual coils) 05) Kutai TS-XXX type ATS	00
3	TDEN Time Delay Emergency to Normal	00 to 250sec	10sec
4	TDNE Time Delay Normal to Emergency	00 to 250sec	10sec
5	TDES Time Delay Engine Start	00 to 30sec	5sec
6	TDEC Time Delay Engine Cool-down	00 to 250sec	30sec
7	Time Delay in the OFF Position	00 to 99sec	5sec
8	Normal over voltage protection setting	11 to 50 (110Vto500V)	25 (250V)
9	Normal Under voltage protection setting	08 to 47 (80Vto470V)	18 (180V)
10	Time delay if there is a problem with the normal voltage	00 to 99sec (0 = disabled voltage monitoring)	10sec
11	Normal over frequency protection setting	51 to 75Hz	65Hz
12	Normal under frequency protection setting	40 to 59Hz	55Hz
13	Time delay if there is a problem with the normal frequency	00 to 99sec (0=disabled Hz monitoring)	10sec
14	Generator over voltage protection setting	11 to 50 (110V to500V)	25 (250V)
15	Generator Under voltage protection setting	8 to 47 (80V to 470V)	18 (180V)
16	Time delay if there is a problem with emergency voltage output	00 to 99sec (0 = Function disabled)	10sec
17	Generator over frequency setting	51 to 75Hz	65Hz
18	Generator under frequency setting	40 to 59Hz	55Hz
19	Time delay if there is a problem with the Generator frequency	00 to 99sec (0 = Function disabled)	10sec
20	Set today's day of the week– Day	1 to 7 (Monday to Sunday)	current
21	Set today's hour – Hour	00 to 23	current
22	Set today's minutes	00 to 59	current
23	Set day of week to do the engine exercise	1 to 7 (Monday to Sunday)	6
24	Set the time to start the exercise	00 to 23 (24 Hr Mode)	12
25	Set Generator automatic exercise cycle	01) 1 week 02) 2 weeks 03) 3 weeks 04) 4 weeks	01
26	Exercising duration	00 to 99 hours (0 = Do not exercise)	00
27	Exercise with load or without load	00) Without load 01) With load	00
28	Test with load or without load	00) Without load 01) With load	01
29	Display Setting	00) Cyclic Mode 01) Fix Mode	00

**ATS-22 AUTOMATIC TRANSFER SWITCH
CONTROL UNIT**

LINE	DESCRIPTION	VALUE	FACTORY SETTING
30	Program the Auxiliary Contact Output	00) Transfer Failure 01) Pre-transfer 02) Pre-exerciser	01
31	Pre-transfer / Pre-exercising time delay before transfer load from one source to another source	00 to 99sec	10
32	Accept remote switch transfer operation (Include emergency stop)	00 → NO 01 → YES	00
33	KCU-02 module address	00 → KCU-02 module restricted 01 to 99	00
34	KCU-02 module transmission rate	01 → 115200 02 → 57600 03 → 38400 04 → 19200 05 → 14400 06 → 9600 07 → 4800 08 → 2400 09 → 1200	03
35	Enter AC Voltage Correction	00 → NO 01 → YES	00

**ATS-22 AUTOMATIC TRANSFER SWITCH
CONTROL UNIT**

3.10 Specification Summary

SUBJECT	SPECIFICATION
AC Voltage Measurement Range	50 VAC to 510 VAC 50/60 HZ
Frequency Measurement Range	40HZ to 75HZ
Remote Start Contact	7A @ 250VAC Max
Normal ON Contact	7A @ 250VAC Max
Emergency ON Contact	7A @ 250VAC Max
Auxiliary Contact Output	7A @ 250VAC Max
Operating Temperature	-20°C to 70°C
Storage Temperature	-30°C to 80°C
Operating Humidity	Maximum 90% relative humidity
Weight	495 g ± 2%

SECTION 4 : INSTALLATION INSTRUCTIONS

4.1 General

The ATS-22 is made for front panel mounting.

4.2 Panel Cut-Out (Unit in millimeter)

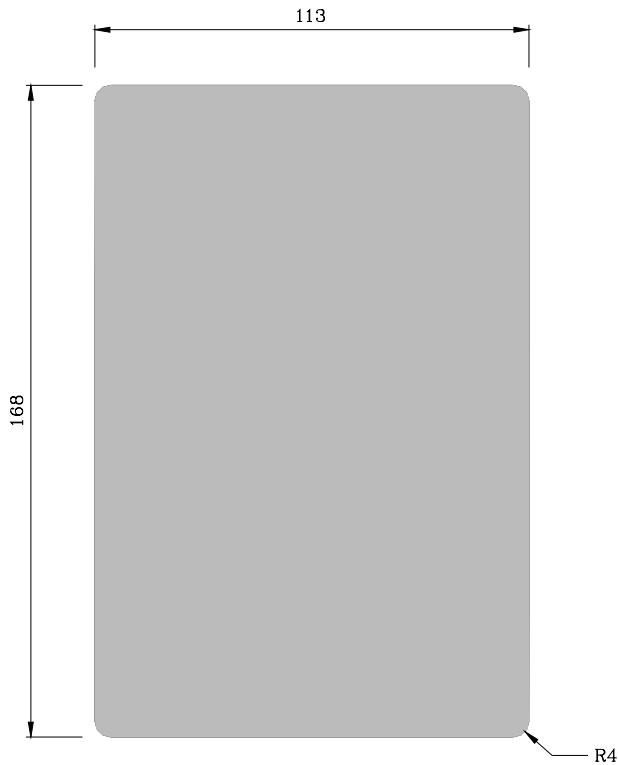

ATS-22 AUTOMATIC TRANSFER SWITCH CONTROL UNIT

4.3 Unit Dimensions (Unit : mm)

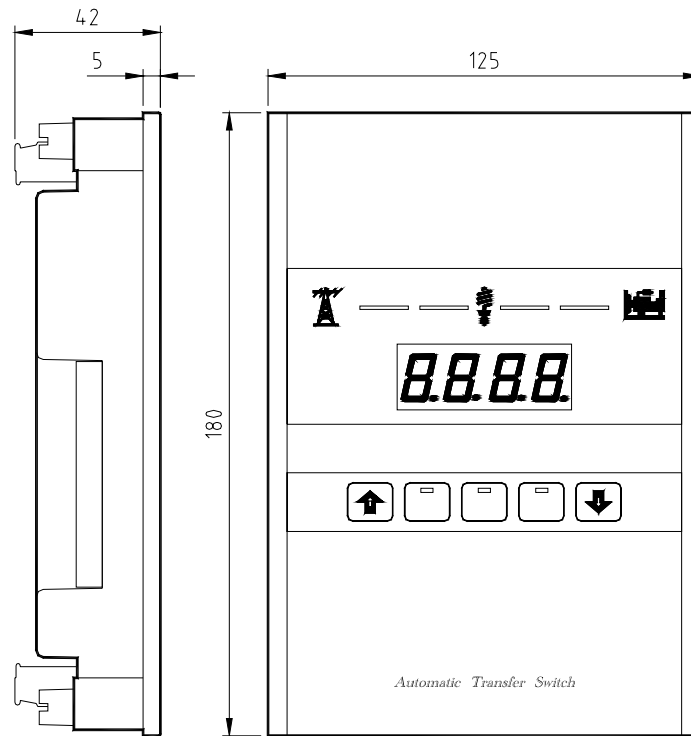

4.4 Installation Reference

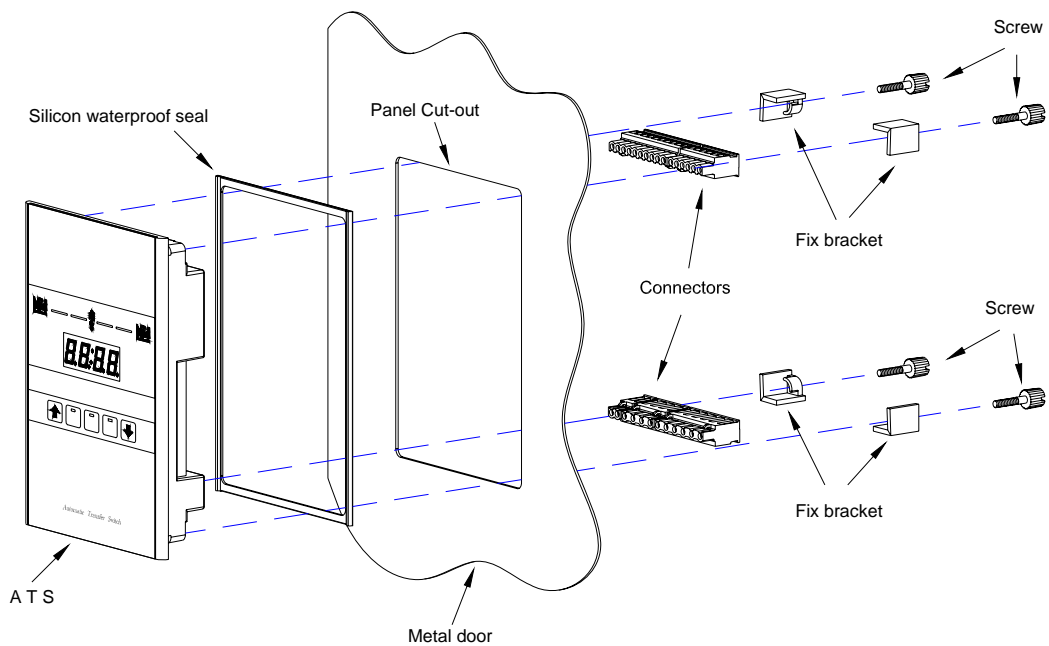

**ATS-22 AUTOMATIC TRANSFER SWITCH
CONTROL UNIT**

SECTION 5 : TYPICAL WIRING

5.1 MCCB Type ATS Wiring Diagram (3P/4P)(220VAC) also called the BTS switch

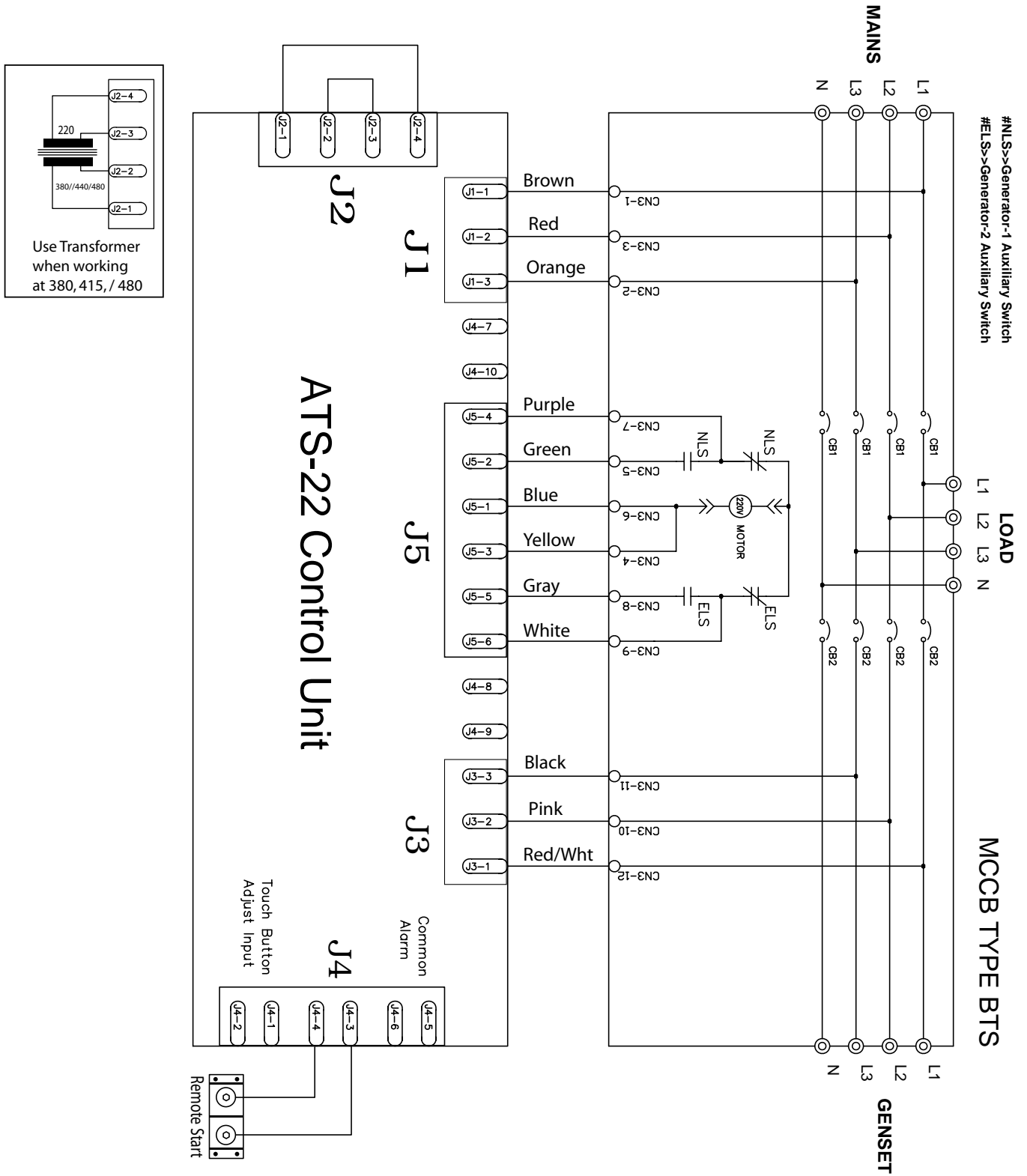

**ATS-22 AUTOMATIC TRANSFER SWITCH
CONTROL UNIT**

5.2 MCCB Type ATS Wiring Diagram (2P)(220VAC)

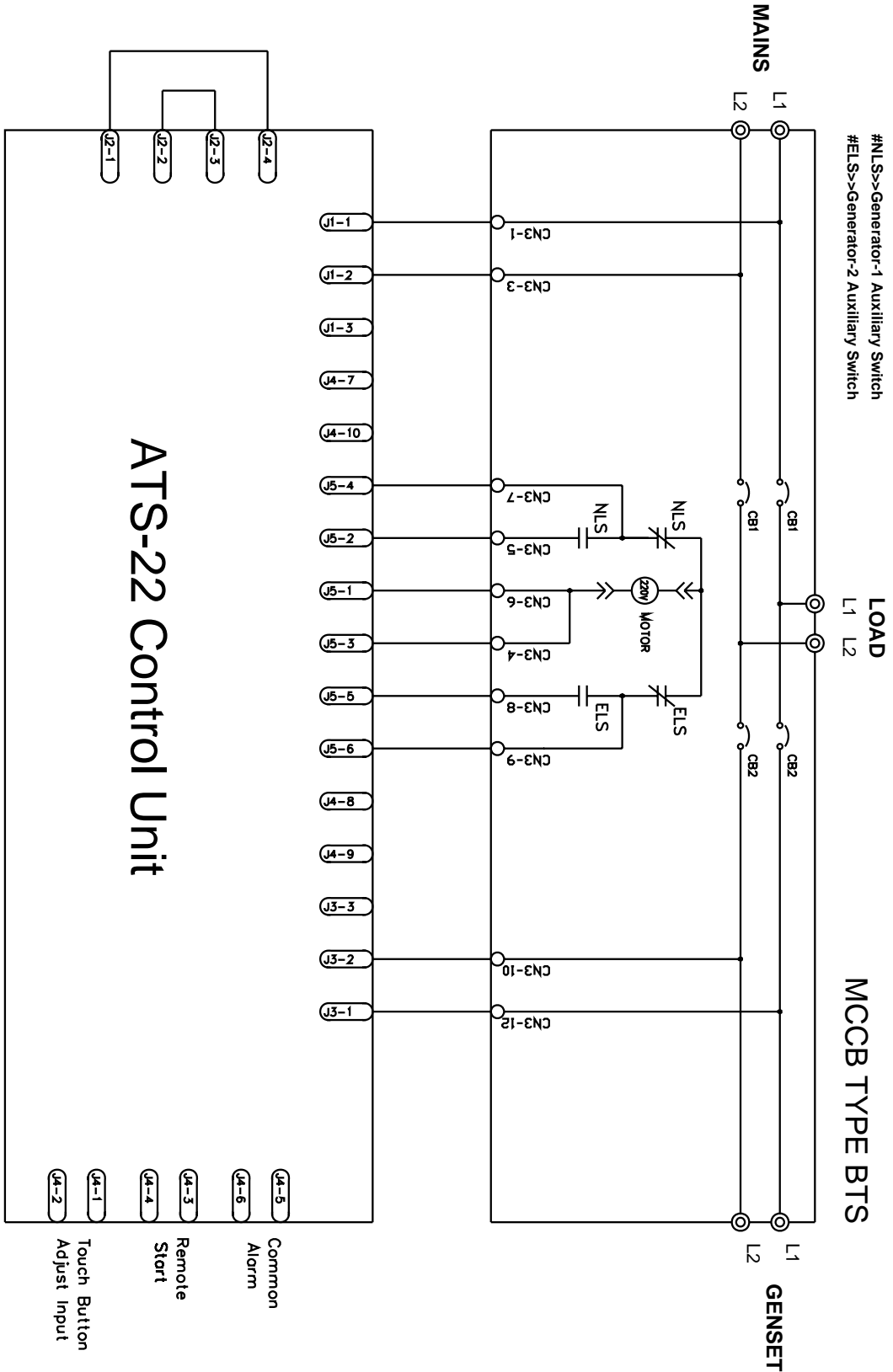

**ATS-22 AUTOMATIC TRANSFER SWITCH
CONTROL UNIT**

5.3 MOT Type ATS Wiring Diagram (3P/4P)(220VAC) Motor Operated MCCB

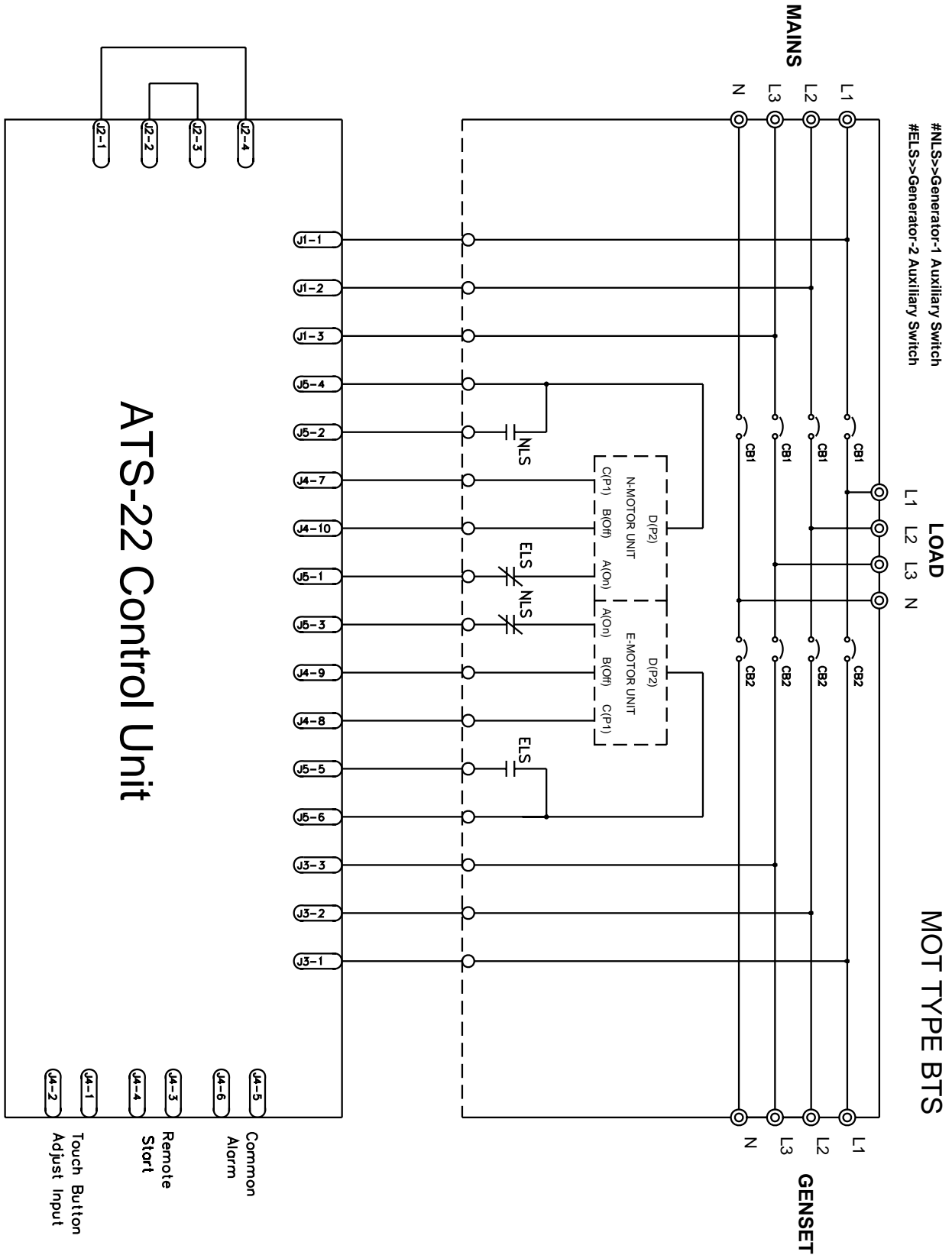

**ATS-22 AUTOMATIC TRANSFER SWITCH
CONTROL UNIT**

5.4 MOT Type ATS Wiring Diagram (2P)(220VAC)

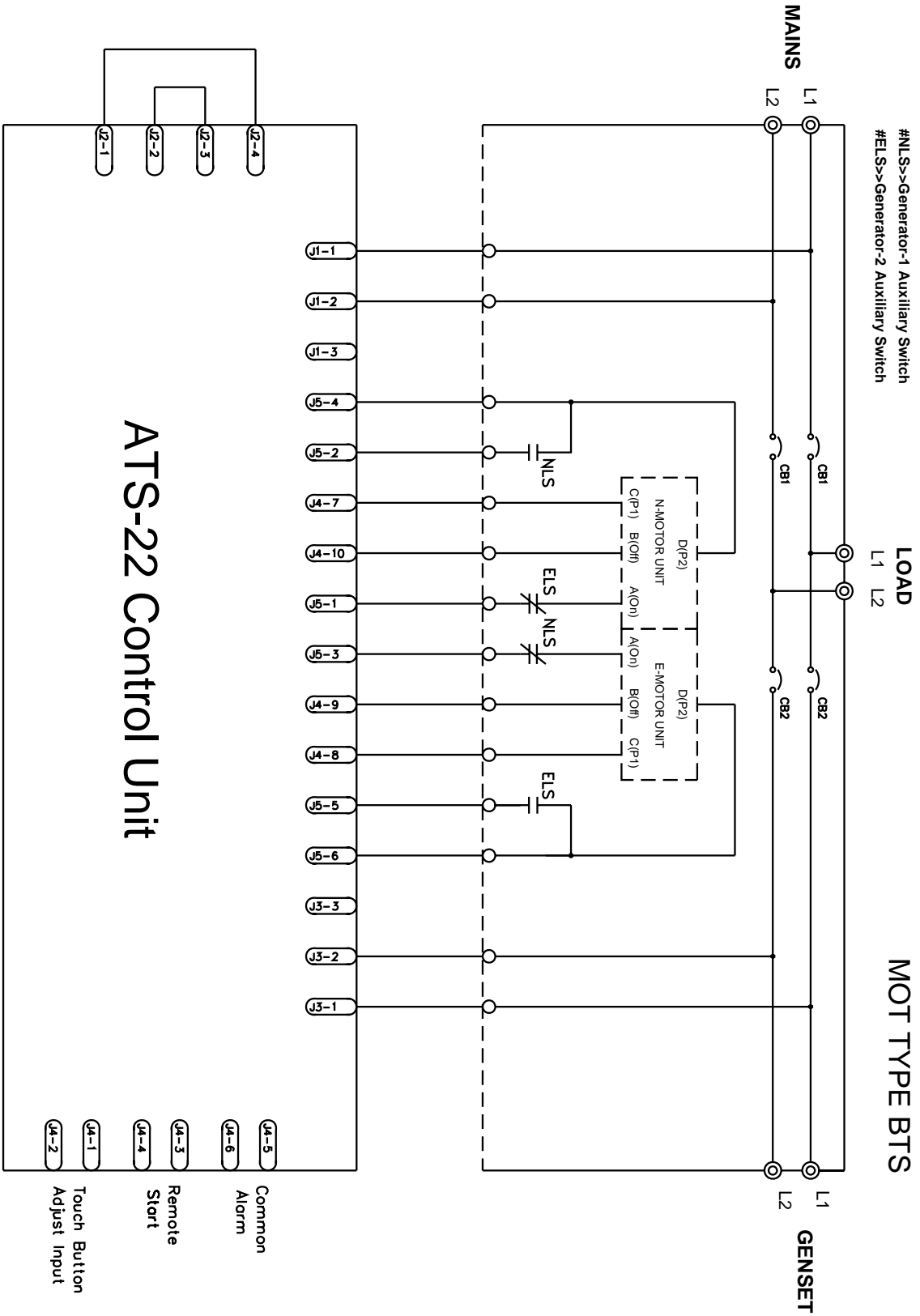

**ATS-22 AUTOMATIC TRANSFER SWITCH
CONTROL UNIT**

5.5 Air Circuit Breaker Type ATS Wiring Diagram (3P/4P)(220VAC)

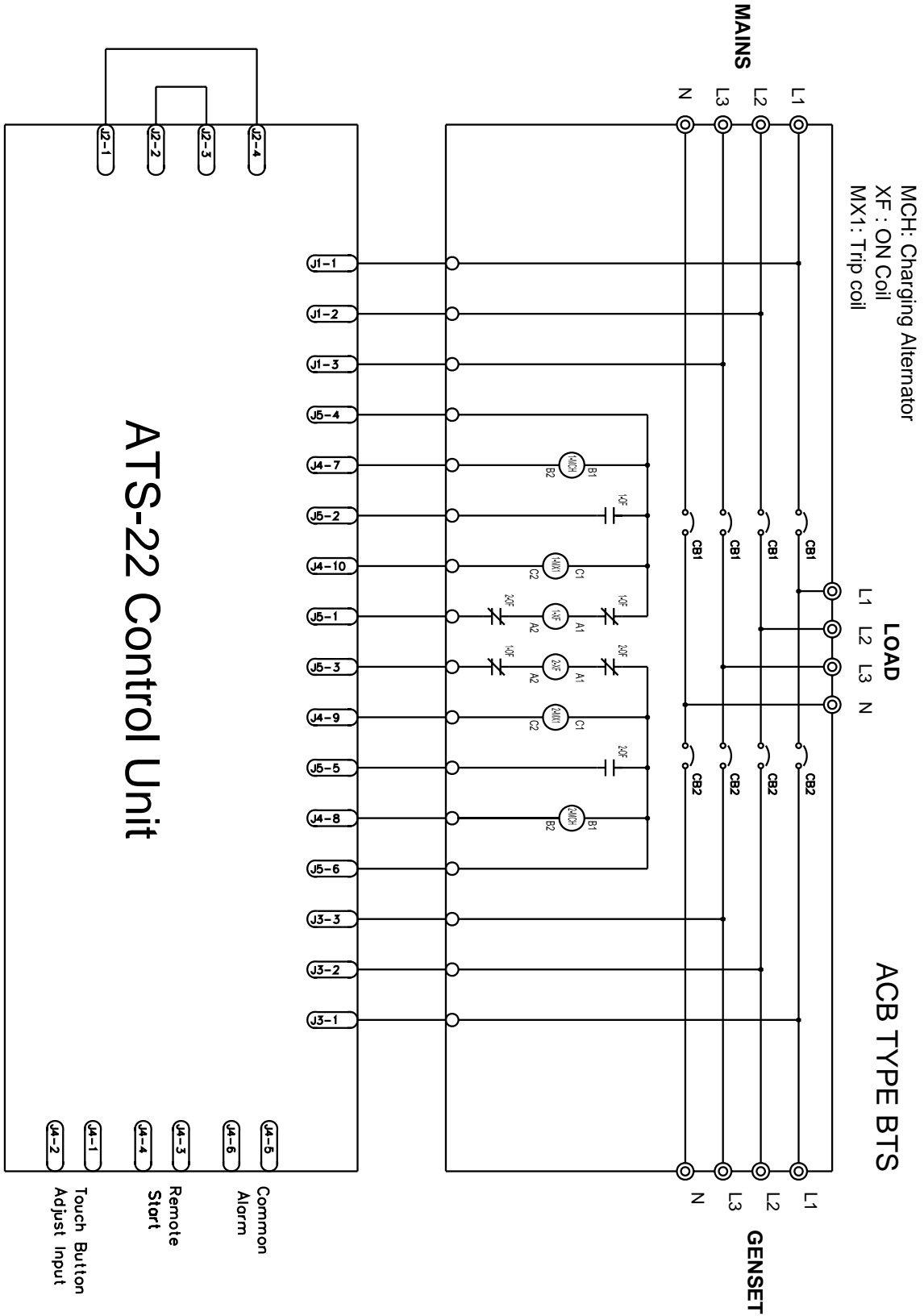

**ATS-22 AUTOMATIC TRANSFER SWITCH
CONTROL UNIT**

5.6 Air Circuit Breaker Type ATS Wiring Diagram (2P)(220VAC)

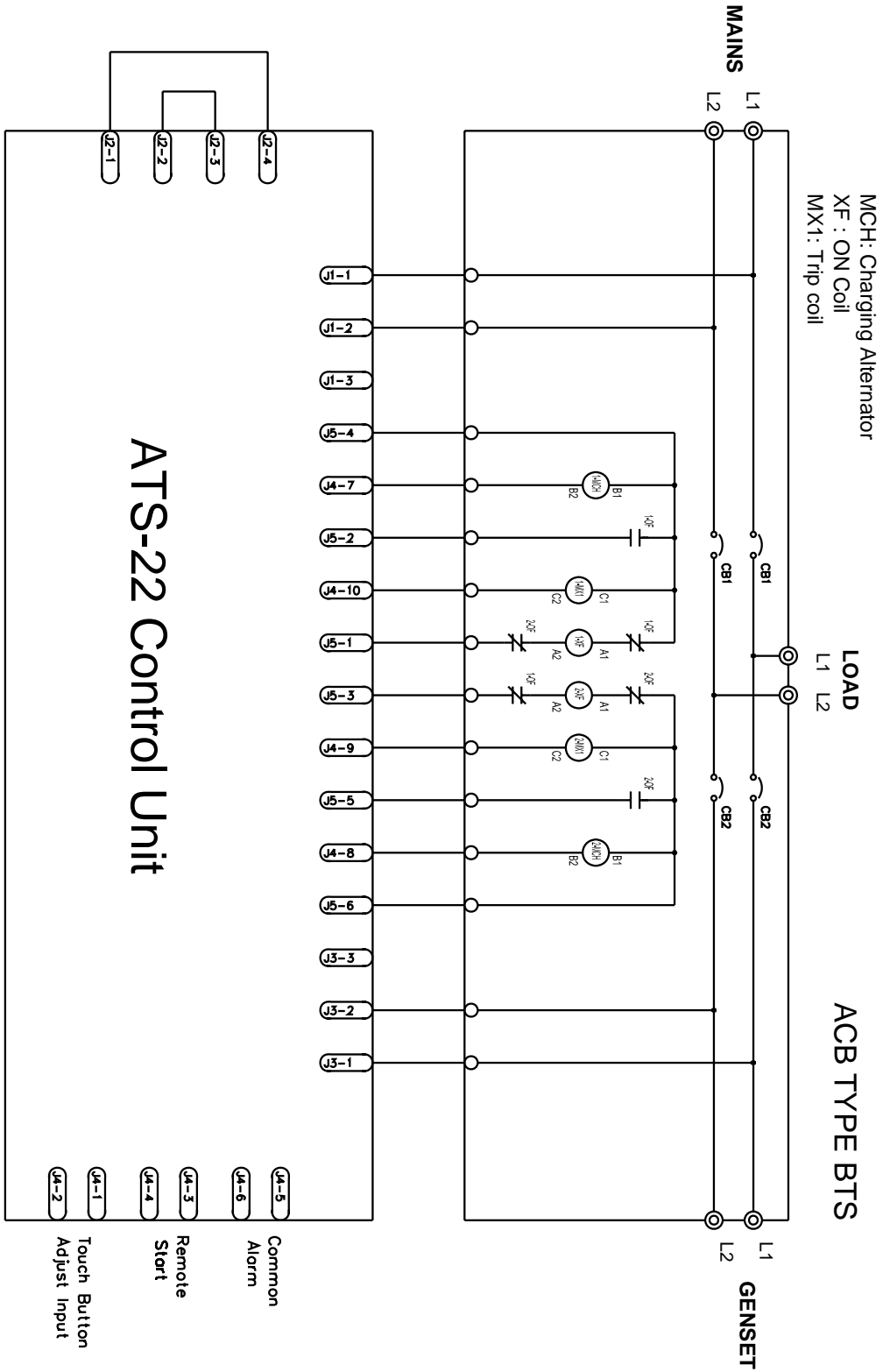

**ATS-22 AUTOMATIC TRANSFER SWITCH
CONTROL UNIT**

5.7 Single Coil Double Throw Type ATS Wiring Diagram (3P/4P)(220VAC)

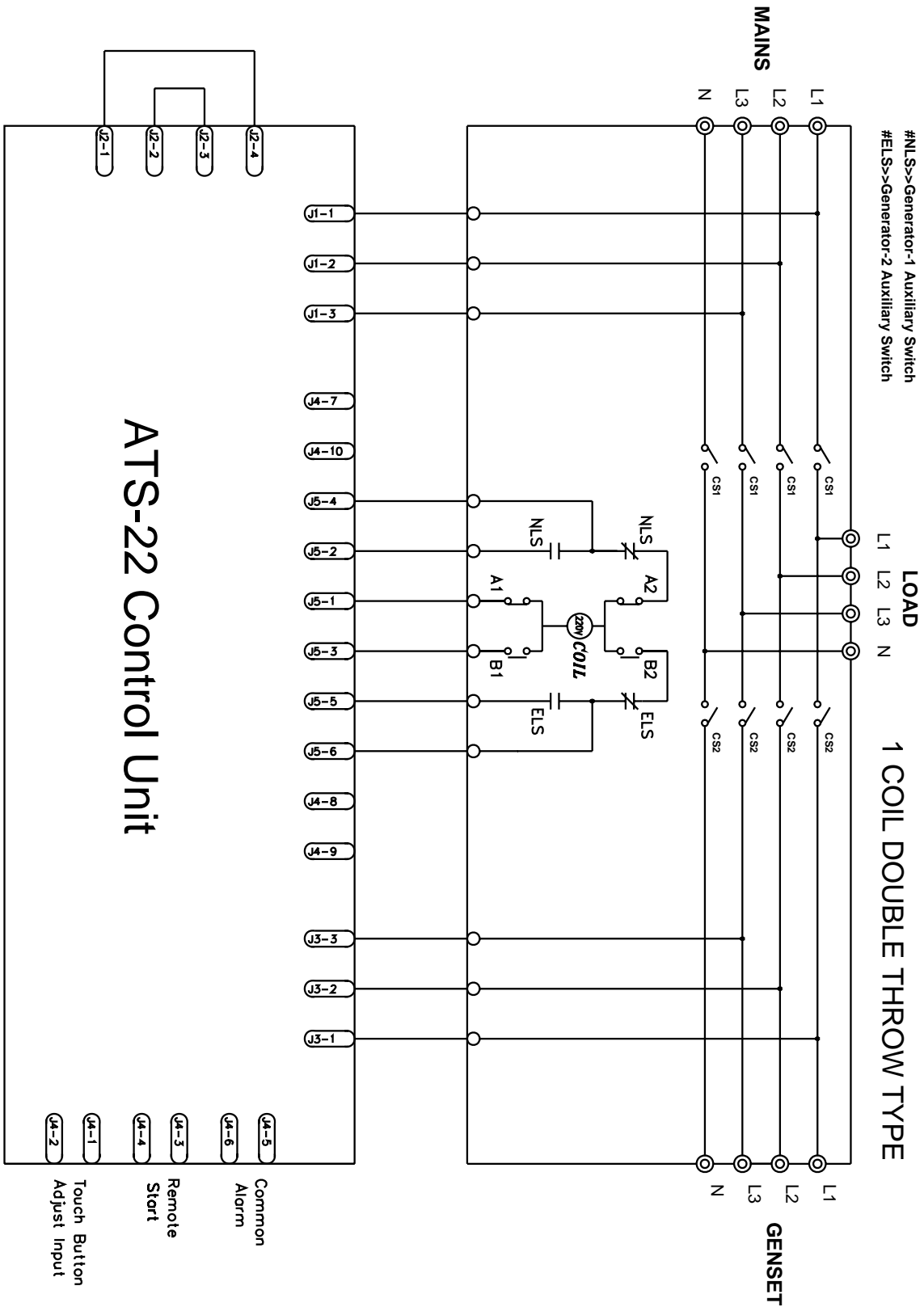

**ATS-22 AUTOMATIC TRANSFER SWITCH
CONTROL UNIT**

5.8 Single Coil Double Throw Type ATS Wiring Diagram (2P)(220VAC)

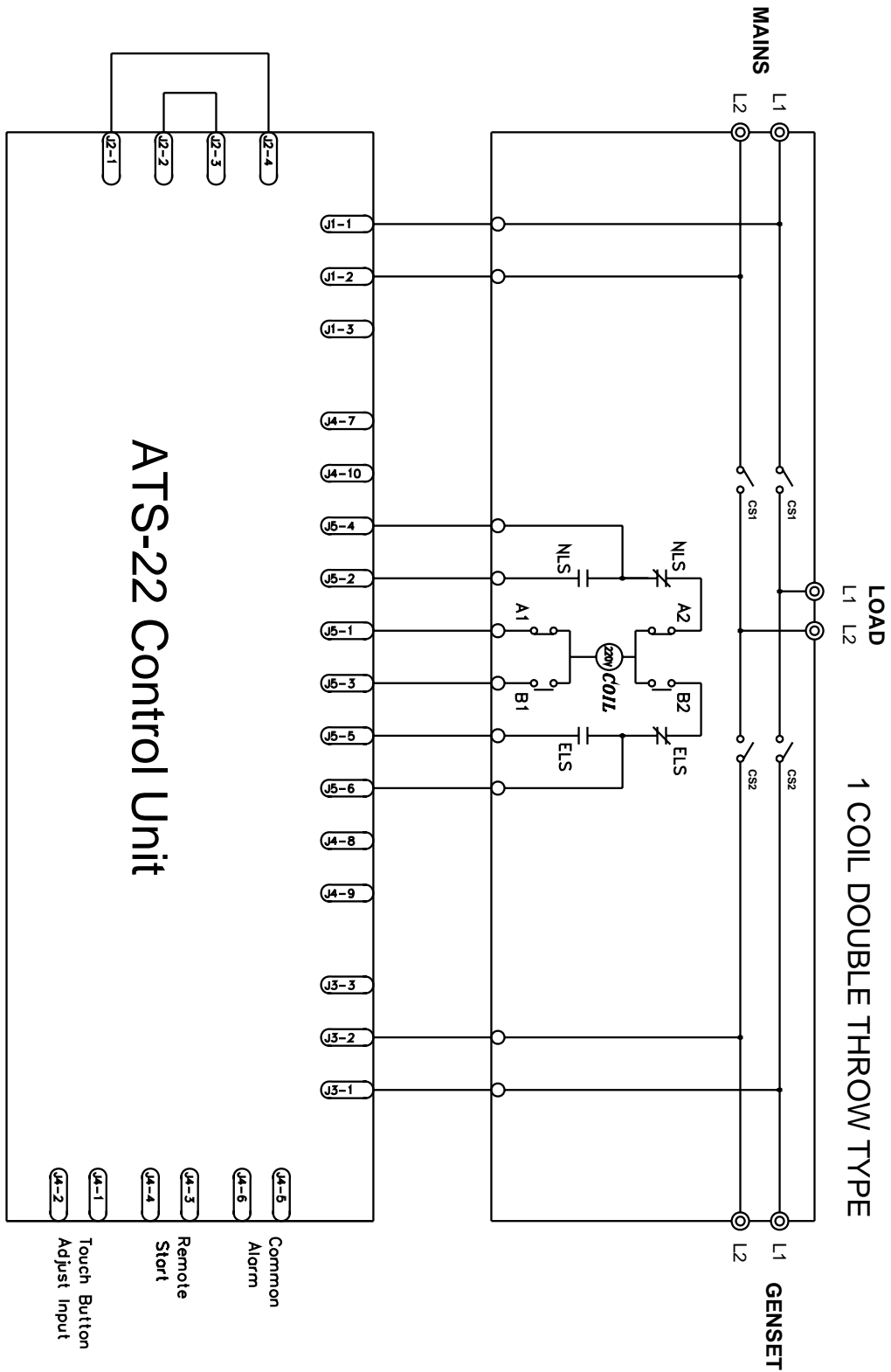

**ATS-22 AUTOMATIC TRANSFER SWITCH
CONTROL UNIT**

5.9 Dual Coil Double Throw Type ATS Wiring Diagram (3P/4P)(220VAC)

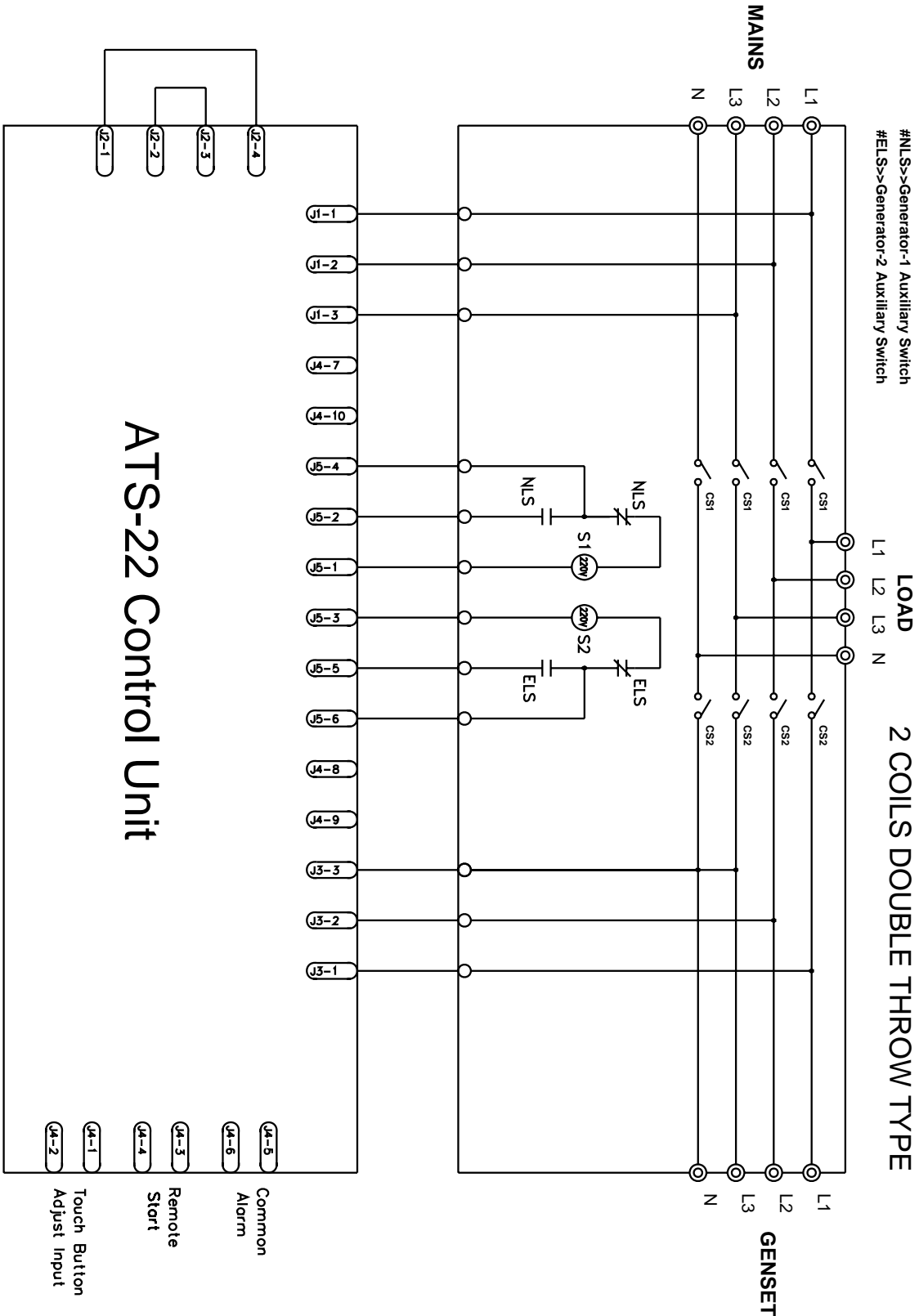

**ATS-22 AUTOMATIC TRANSFER SWITCH
CONTROL UNIT**

5.10 Dual Coil Double Throw Type ATS Wiring Diagram (2P)(220VAC)

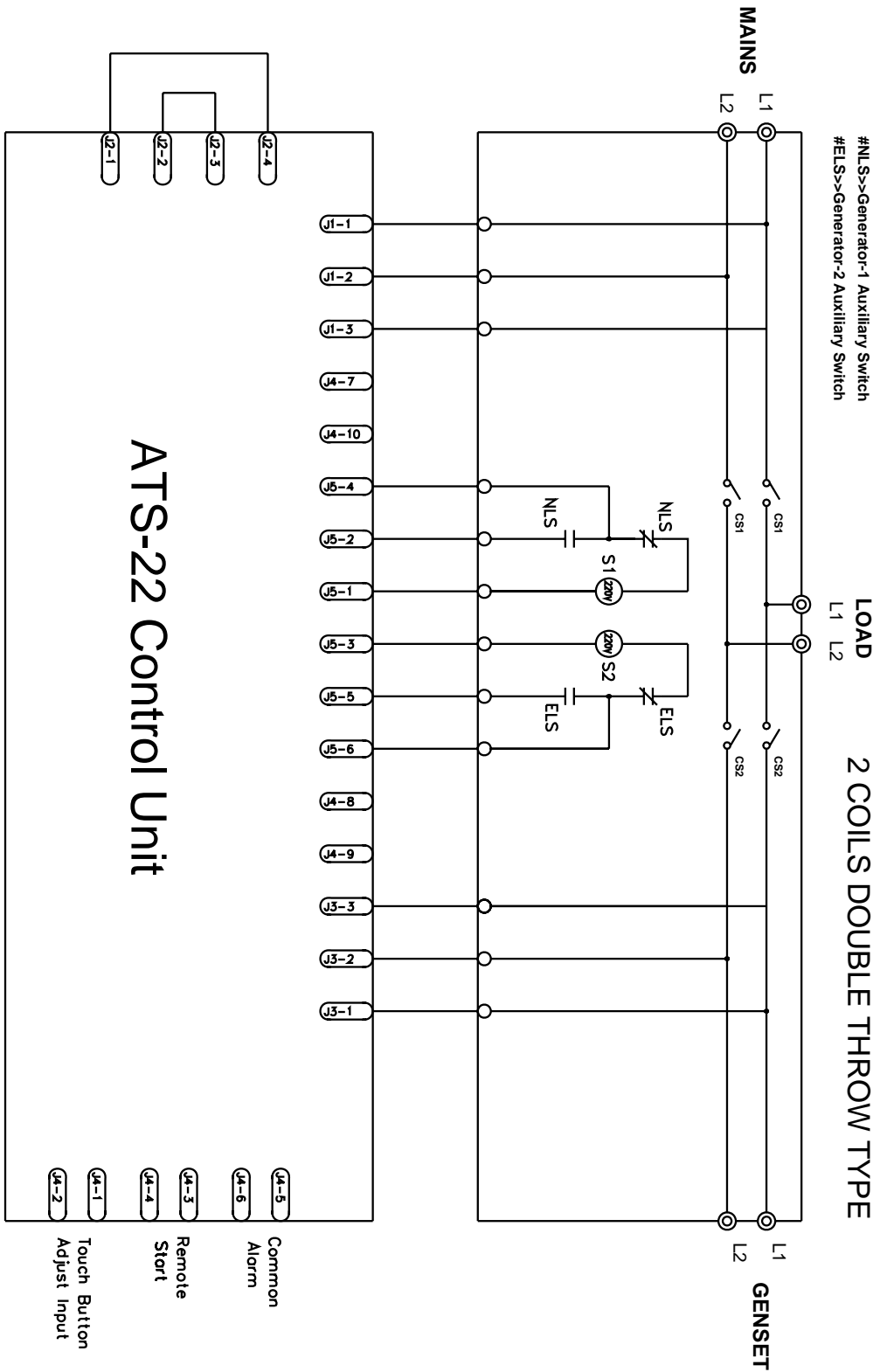

**ATS-22 AUTOMATIC TRANSFER SWITCH
CONTROL UNIT**

5.11 KUTAI TS-XXX Type ATS Wiring Diagram (3P/4P)(220VAC)

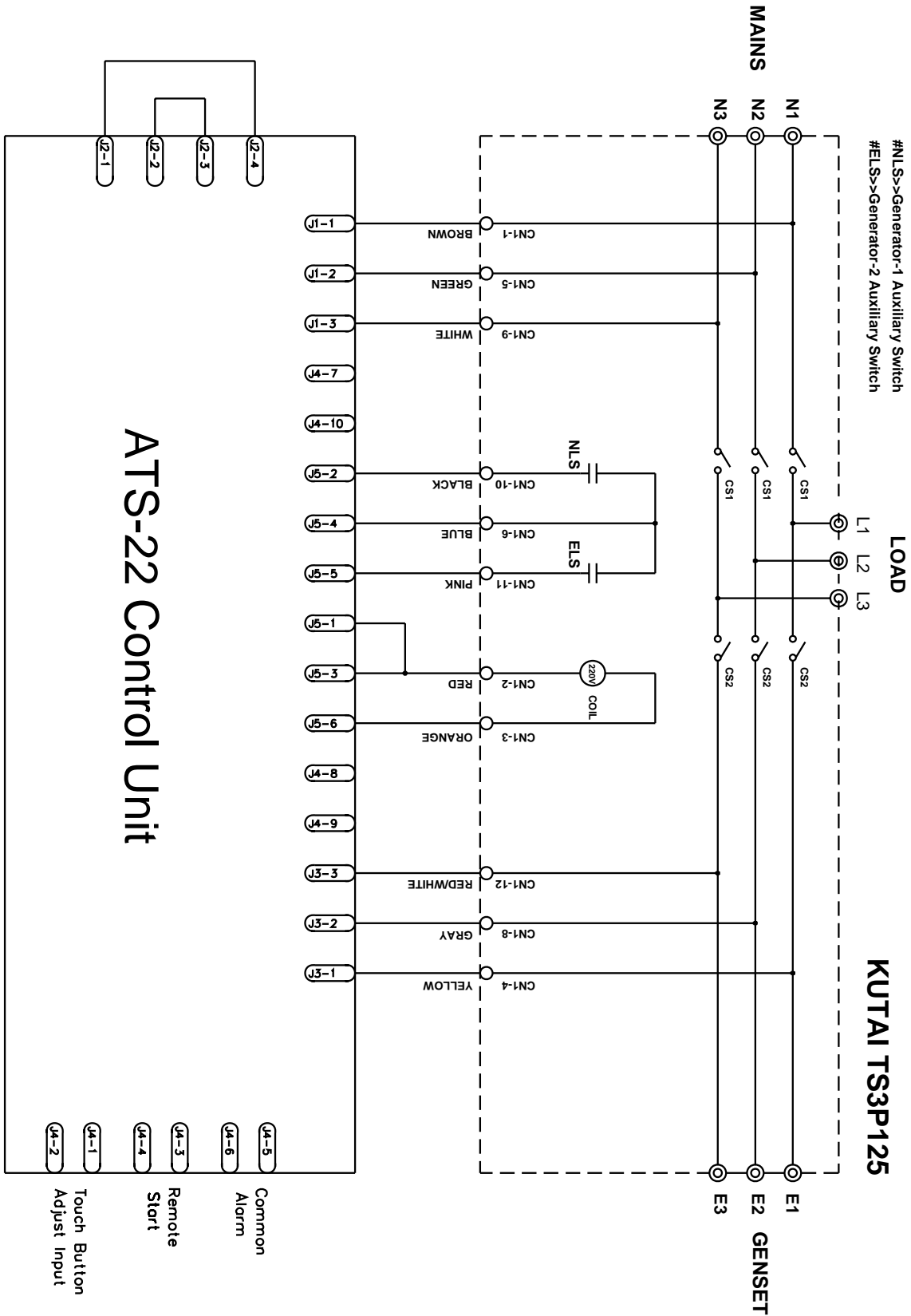

**ATS-22 AUTOMATIC TRANSFER SWITCH
CONTROL UNIT**

5.12 KUTAI TS-XXX Type ATS Wiring Diagram (2P)(220VAC)

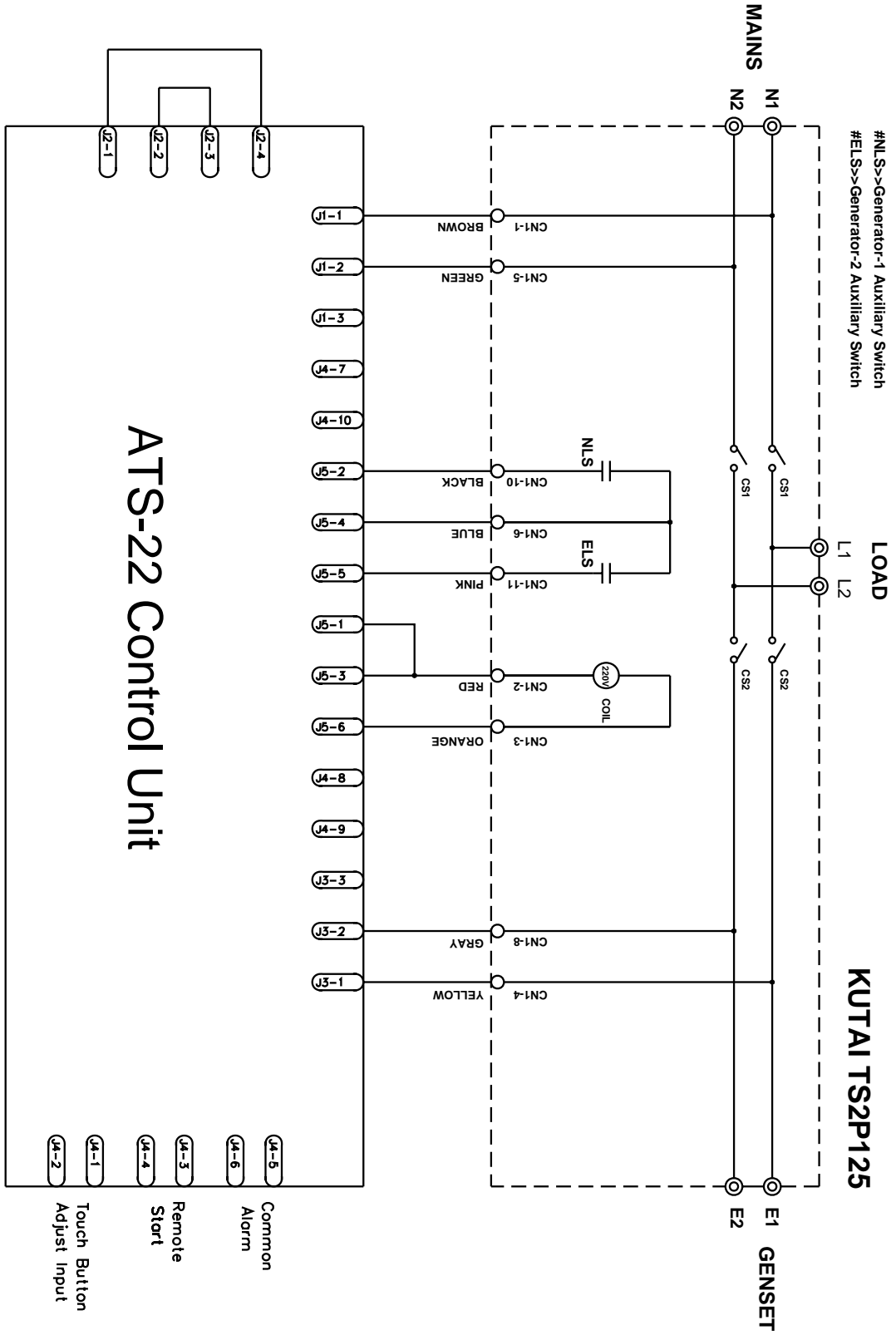

**ATS-22 AUTOMATIC TRANSFER SWITCH
CONTROL UNIT**

5.13 KME WN Type and AICHI WN type ATS Wiring Diagram (3P/4P)(220VAC)

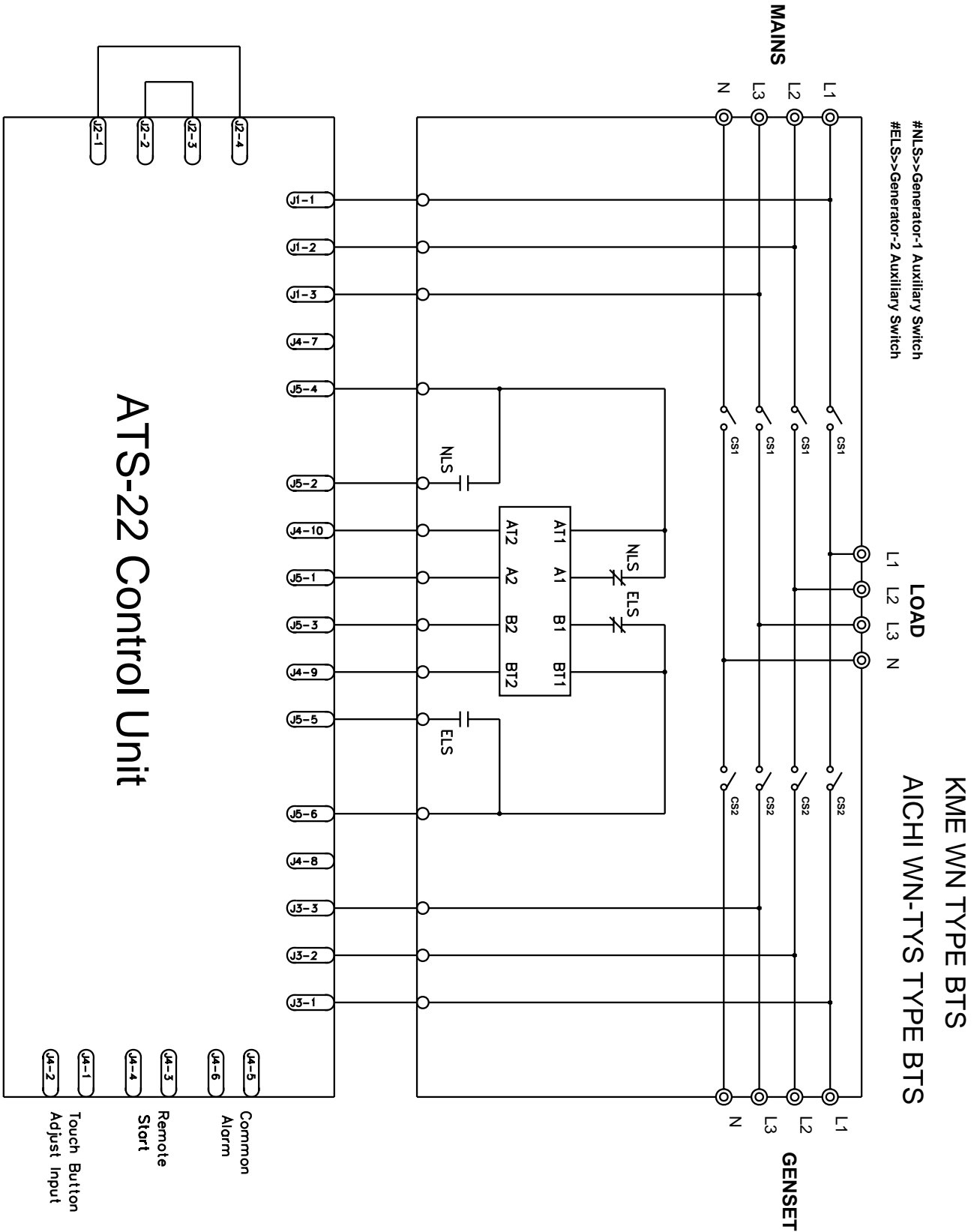

**ATS-22 AUTOMATIC TRANSFER SWITCH
CONTROL UNIT**

5.14 KME WN Type and AICHI WN type ATS Wiring Diagram (2P)(220VAC)

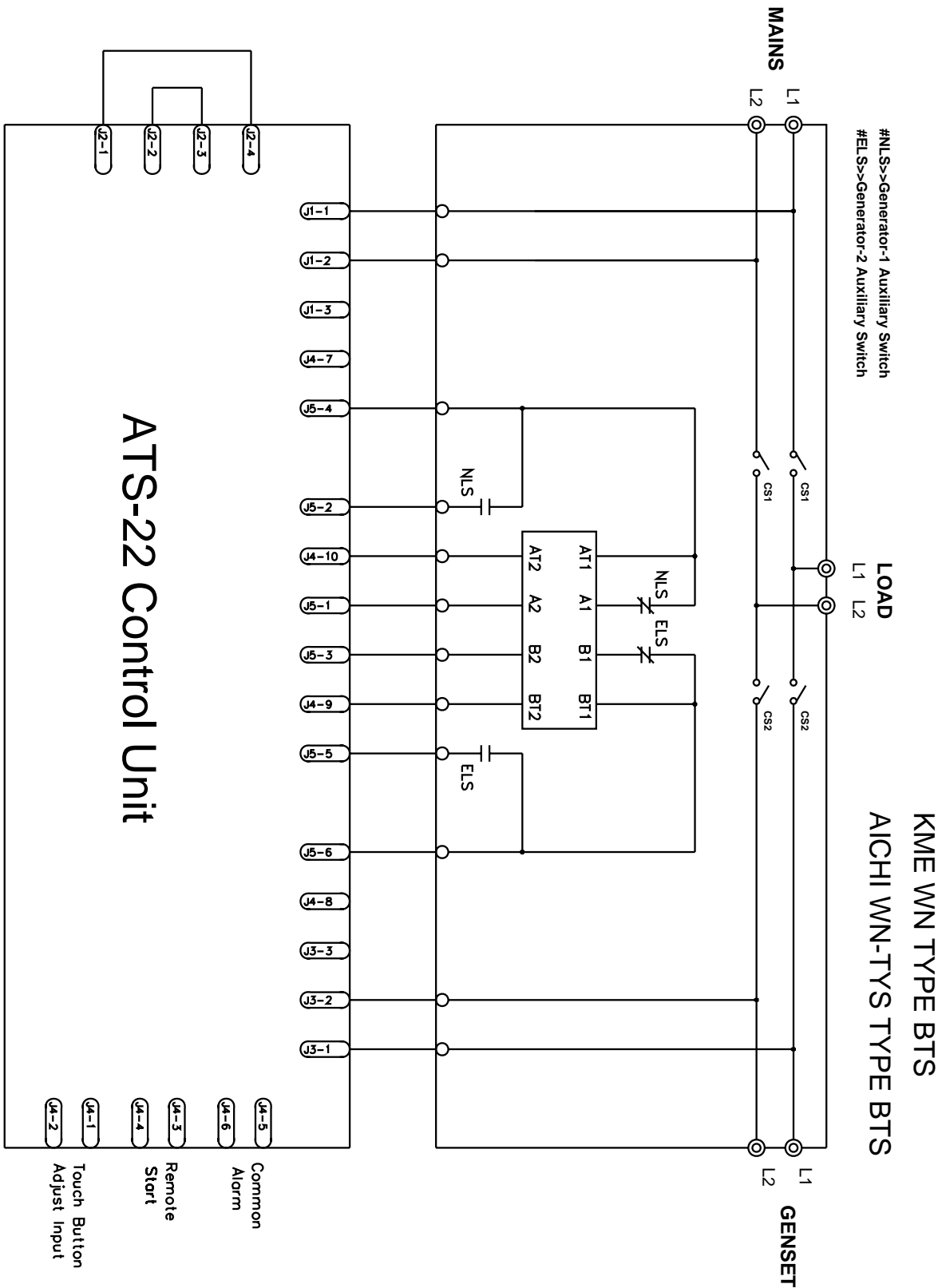

**ATS-22 AUTOMATIC TRANSFER SWITCH
CONTROL UNIT**

5.15 SOCOMEC ATyS-3S type ATS Wiring Diagram (3P/4P)(220VAC)

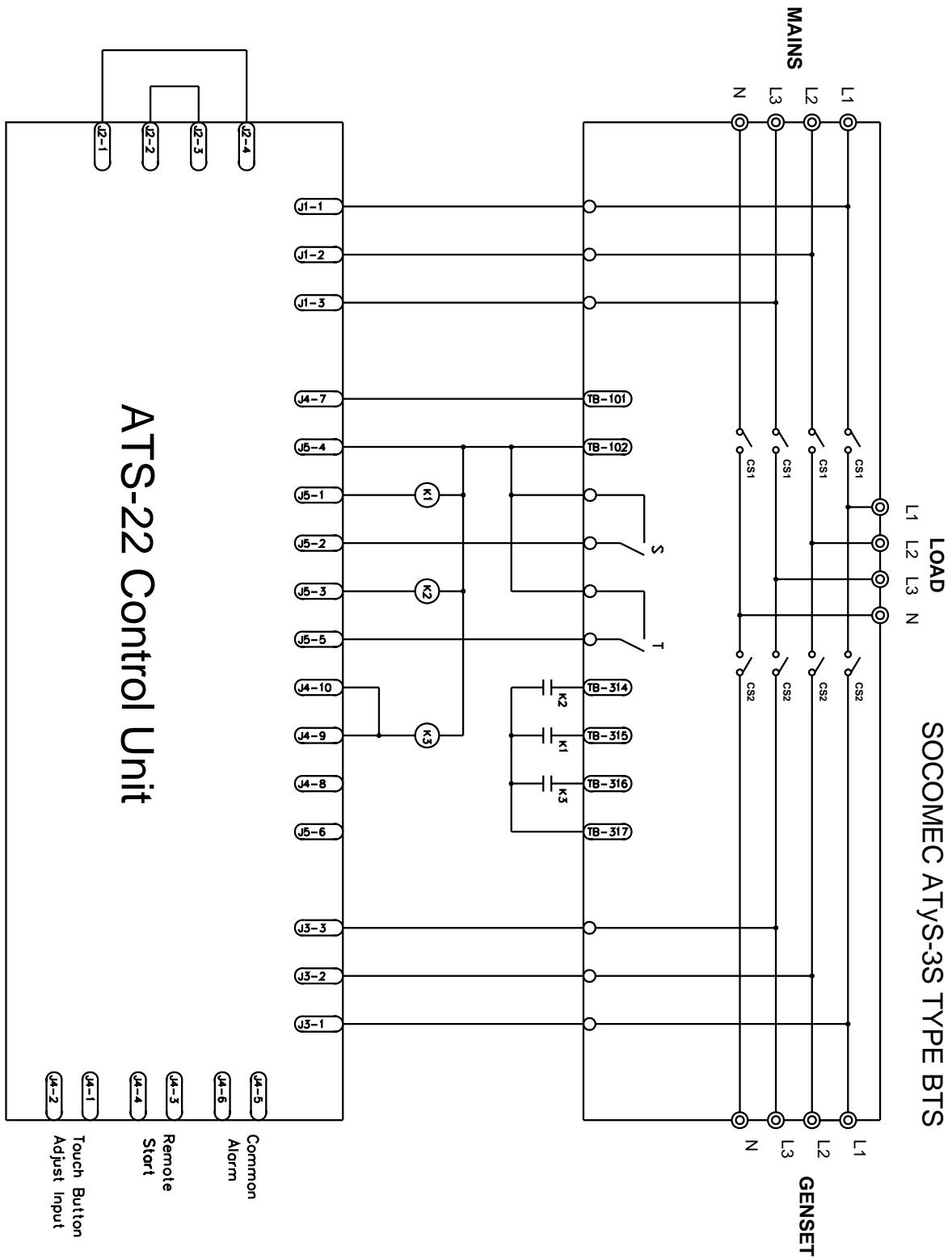

**ATS-22 AUTOMATIC TRANSFER SWITCH
CONTROL UNIT**

5.16 SOCOMEC ATyS-3S type ATS Wiring Diagram (2P)(220VAC)

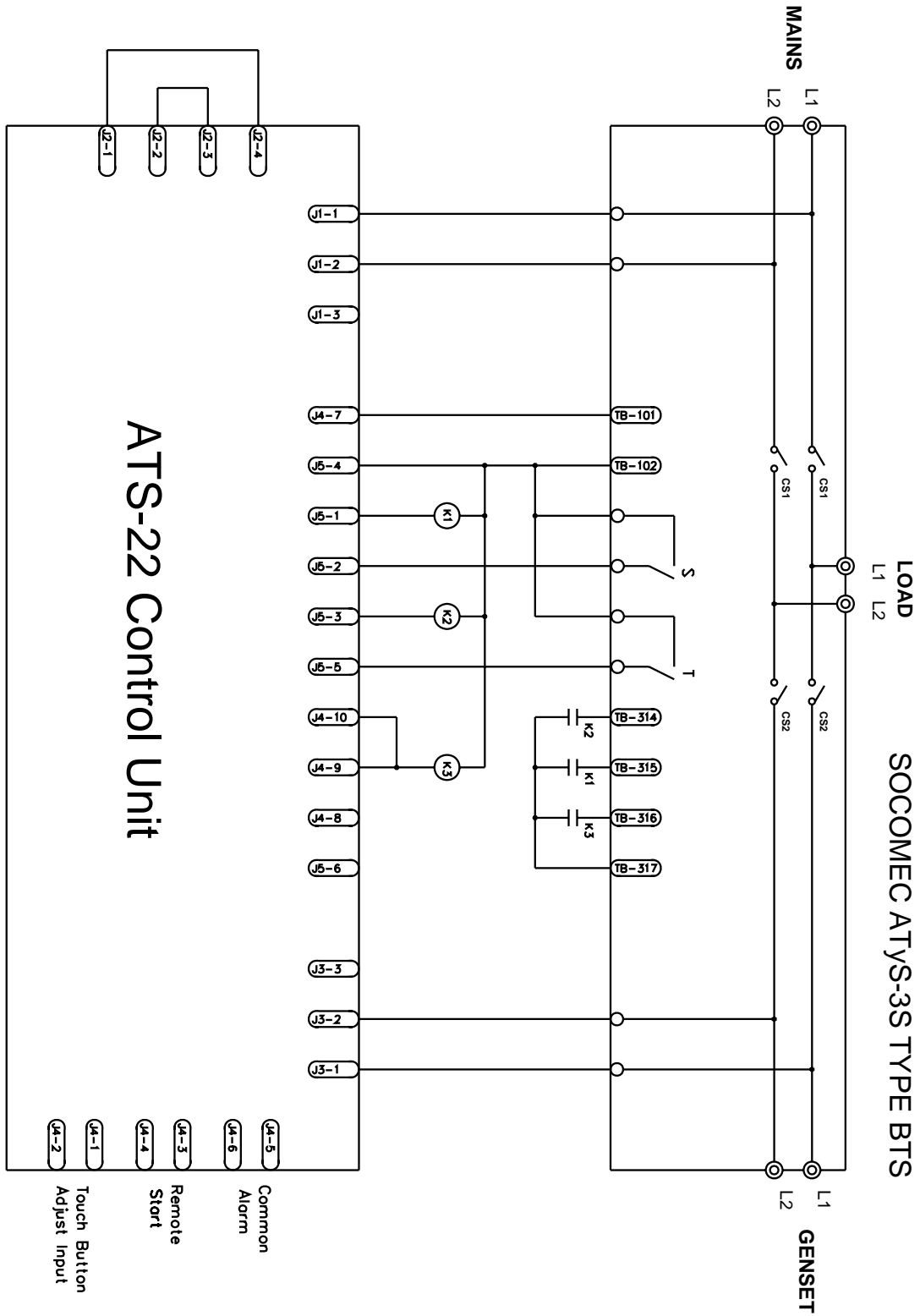

ATS-22 AUTOMATIC TRANSFER SWITCH
CONTROL UNIT

5.17 SOCOMEC ATyS-3e type ATS Wiring Diagram (3P/4P)(220VAC)

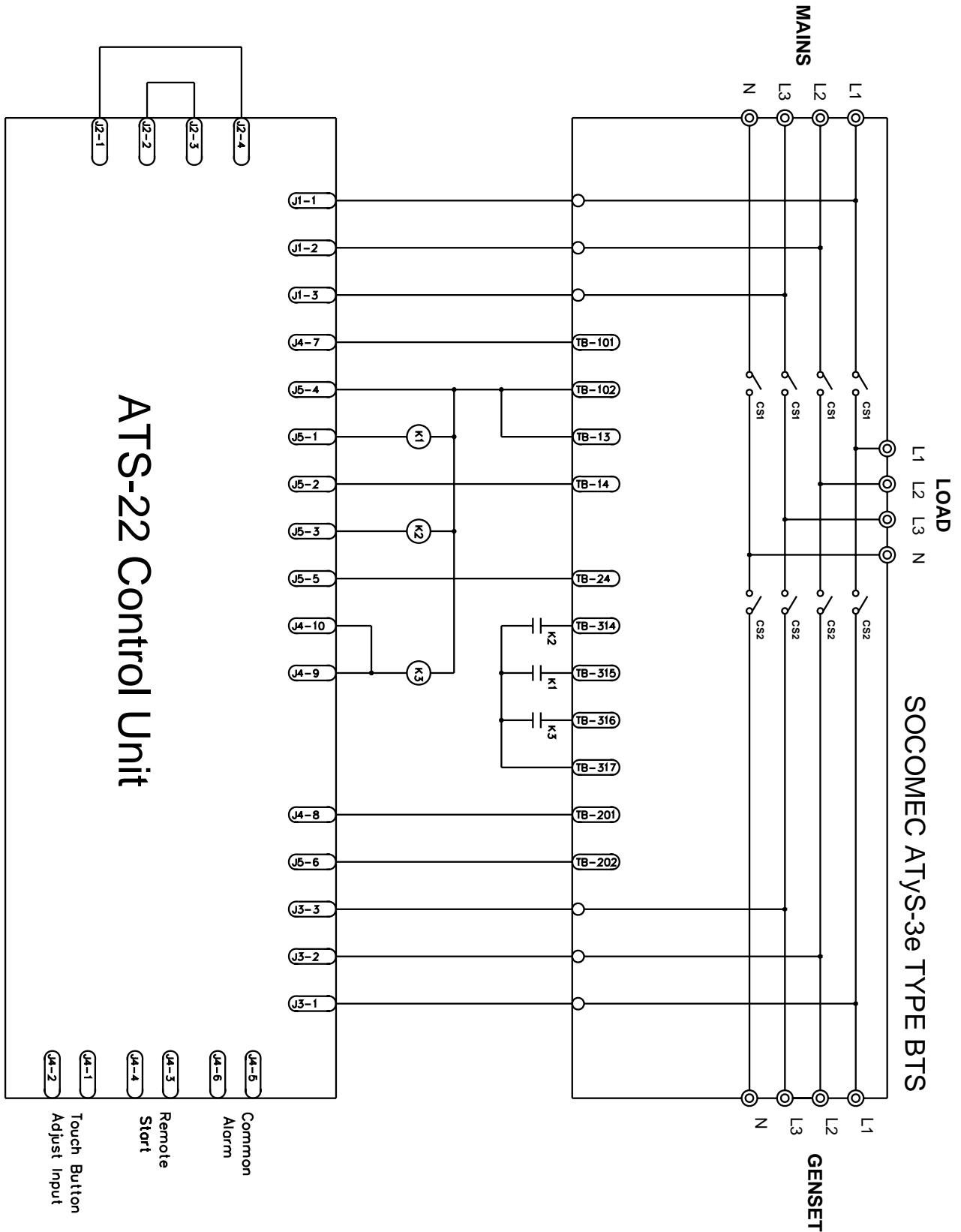

ATS-22 AUTOMATIC TRANSFER SWITCH
CONTROL UNIT

5.18 SOCOMEC ATyS-3e type ATS Wiring Diagram (2P)(220VAC)

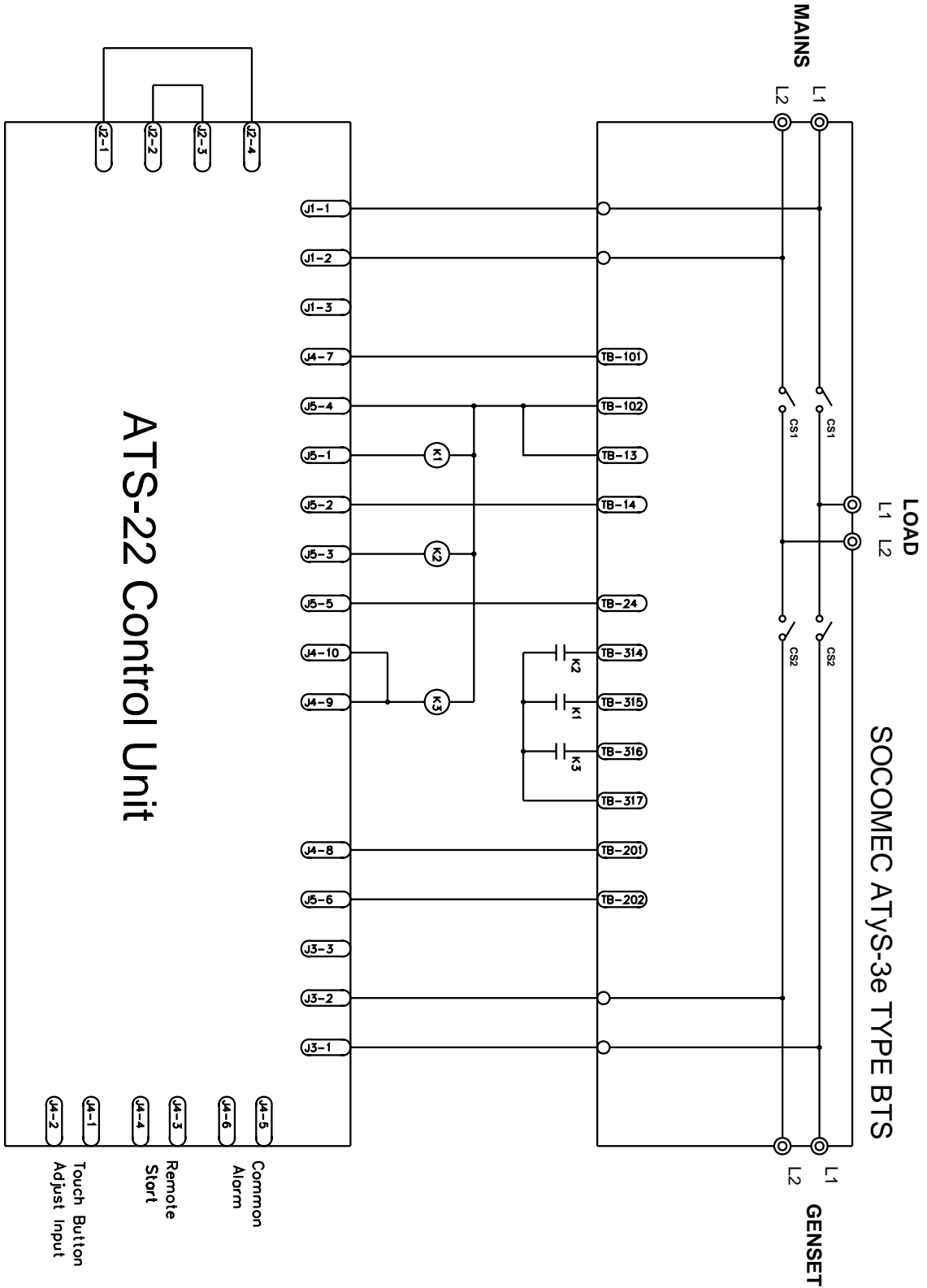

**ATS-22 AUTOMATIC TRANSFER SWITCH
CONTROL UNIT**

5.19 SOCOMEC ATyS-6 type ATS Wiring Diagram (3P/4P)(220VAC)

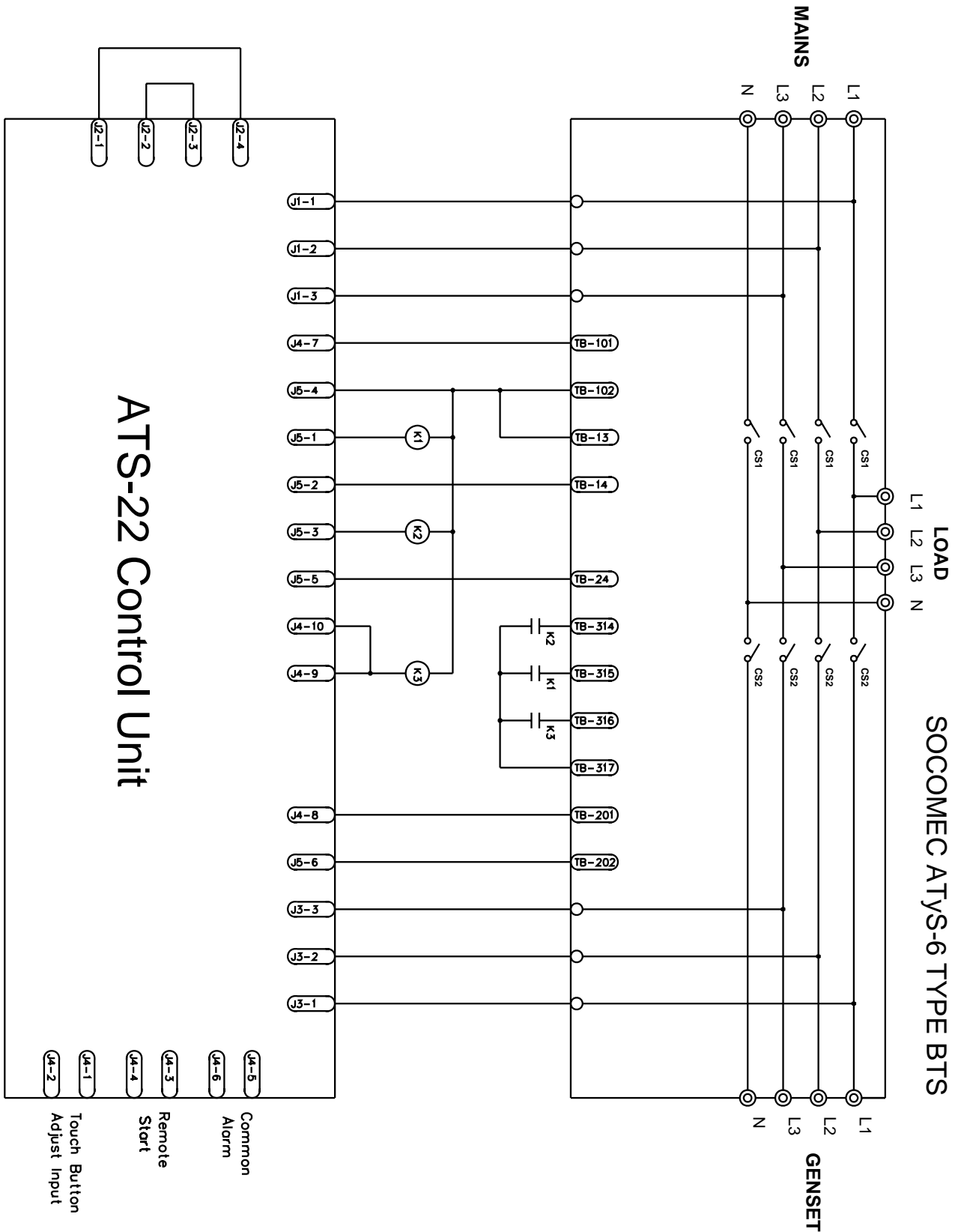

ATS-22 AUTOMATIC TRANSFER SWITCH
CONTROL UNIT

5.20 SOCOMEC ATyS-6 type ATS Wiring Diagram (2P)(220VAC)

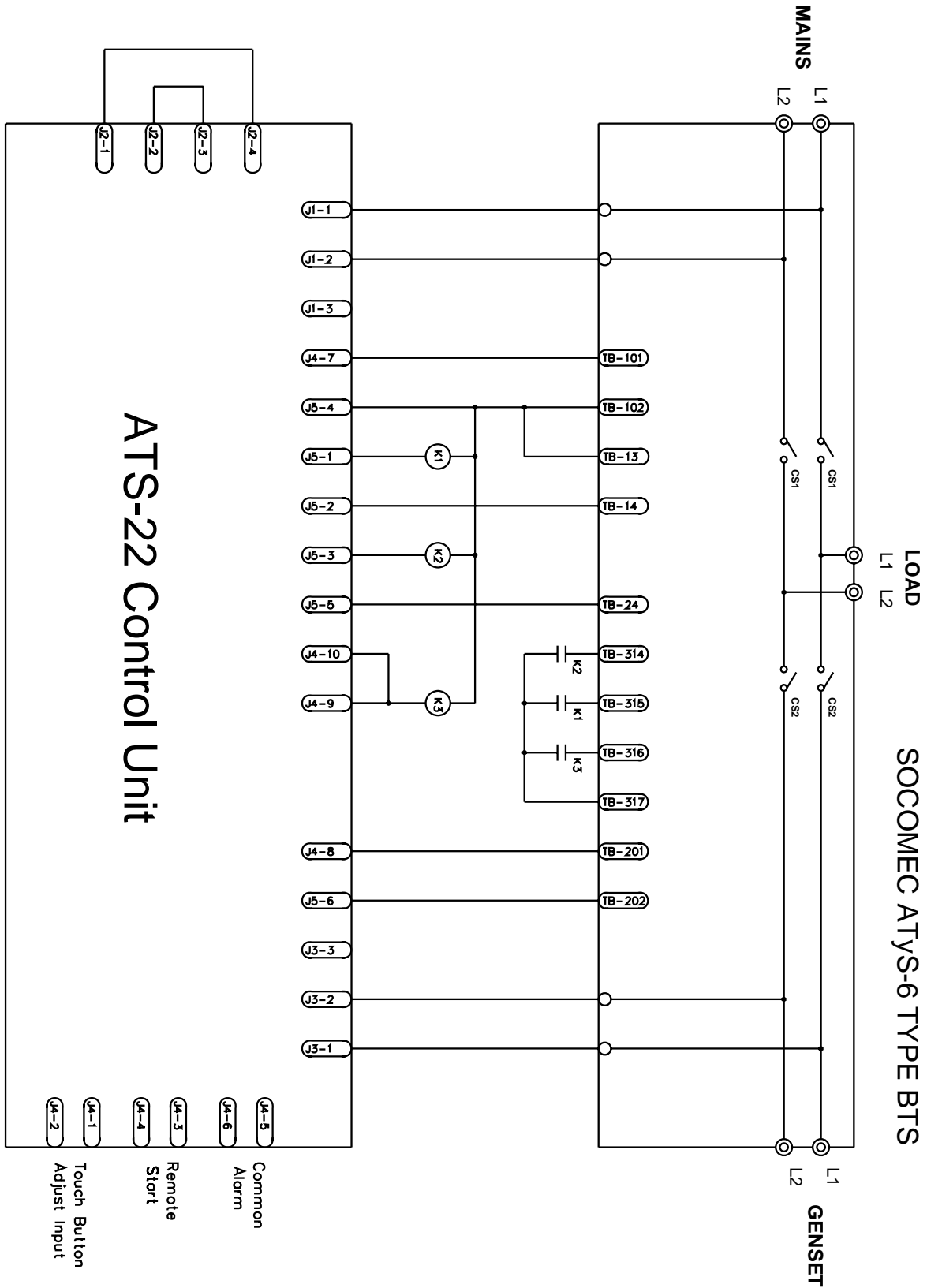

**ATS-22 AUTOMATIC TRANSFER SWITCH
CONTROL UNIT**

5.21 SOCOMEC ATyS-6e type ATS Wiring Diagram (3P/4P)(220VAC)

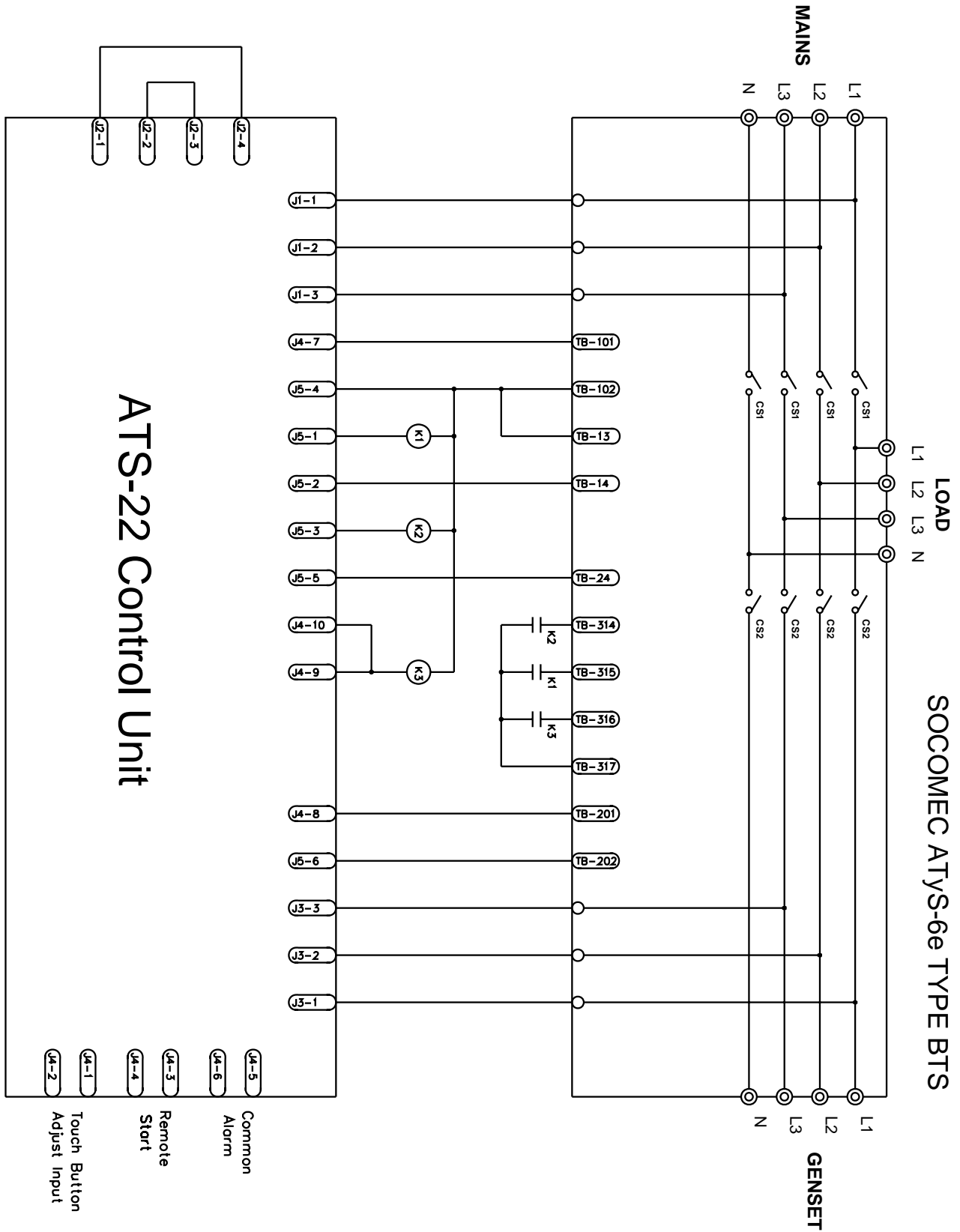

**ATS-22 AUTOMATIC TRANSFER SWITCH
CONTROL UNIT**

5.22 SOCOMEC ATyS-6e type ATS Wiring Diagram (2P)(220VAC)

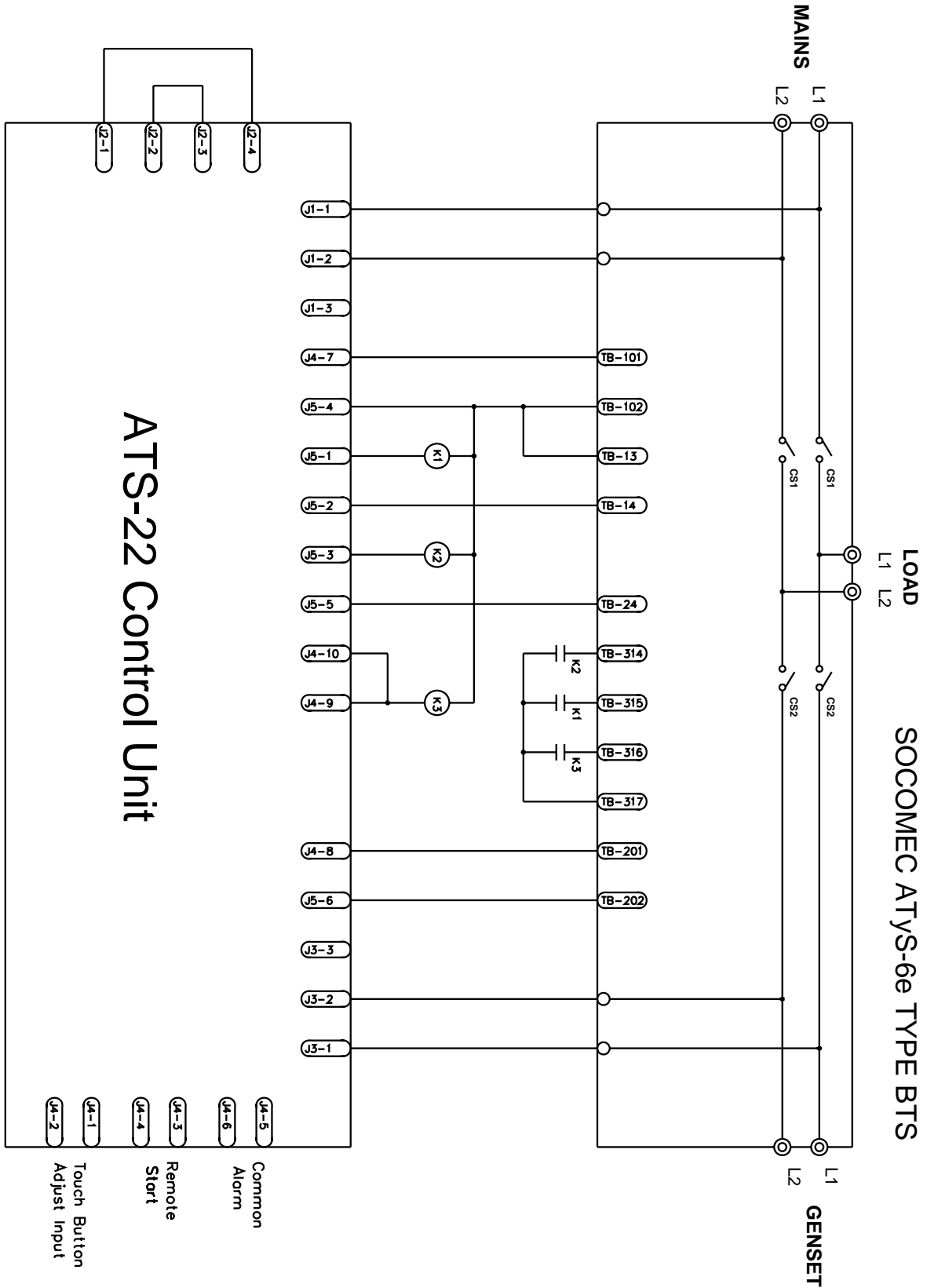

**ATS-22 AUTOMATIC TRANSFER SWITCH
CONTROL UNIT**

5.23 MITSUBISHI MD type ATS Wiring Diagram (3P/4P)(220VAC)

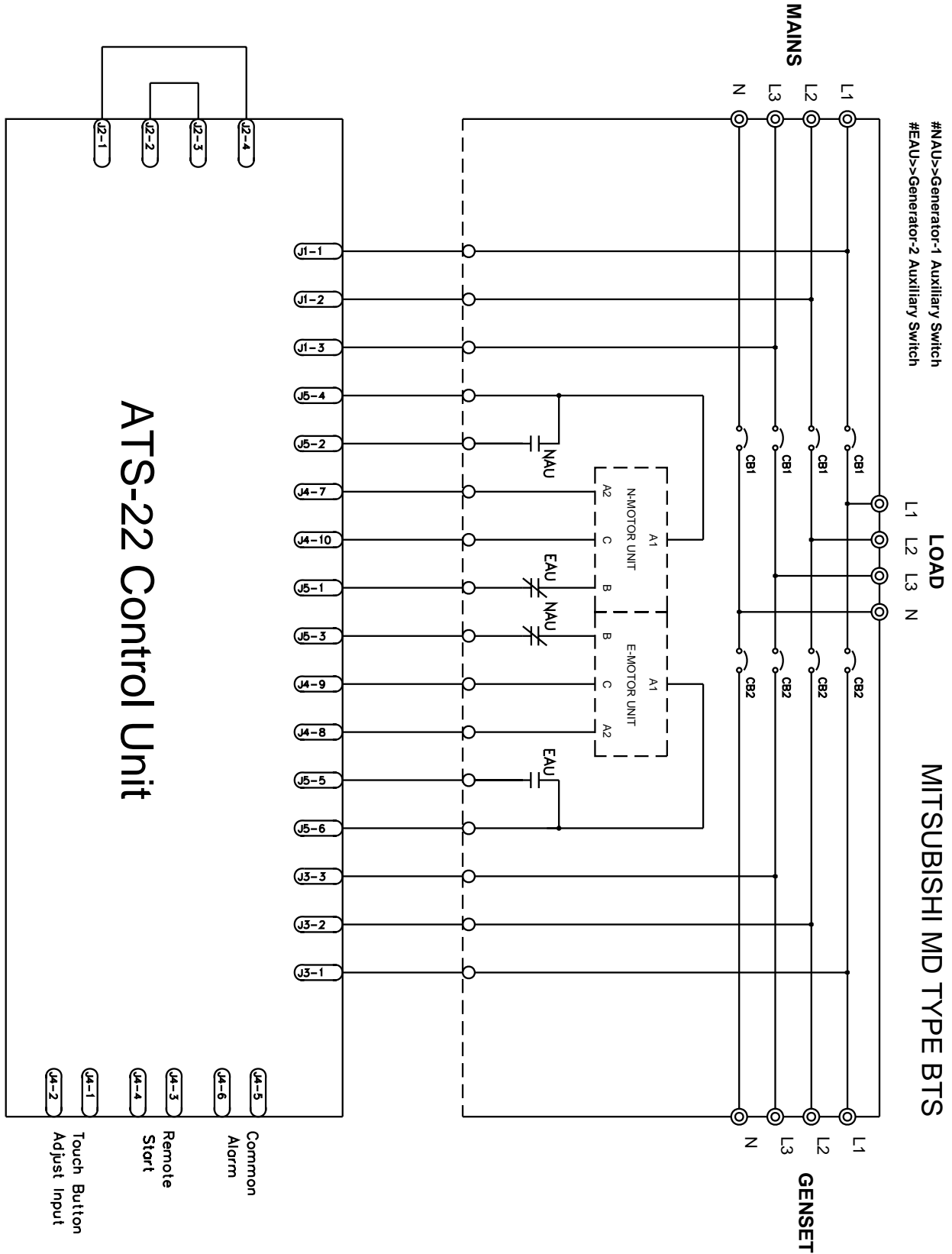

**ATS-22 AUTOMATIC TRANSFER SWITCH
CONTROL UNIT**

5.24 MITSUBISHI MD type ATS Wiring Diagram (2P)(220VAC)

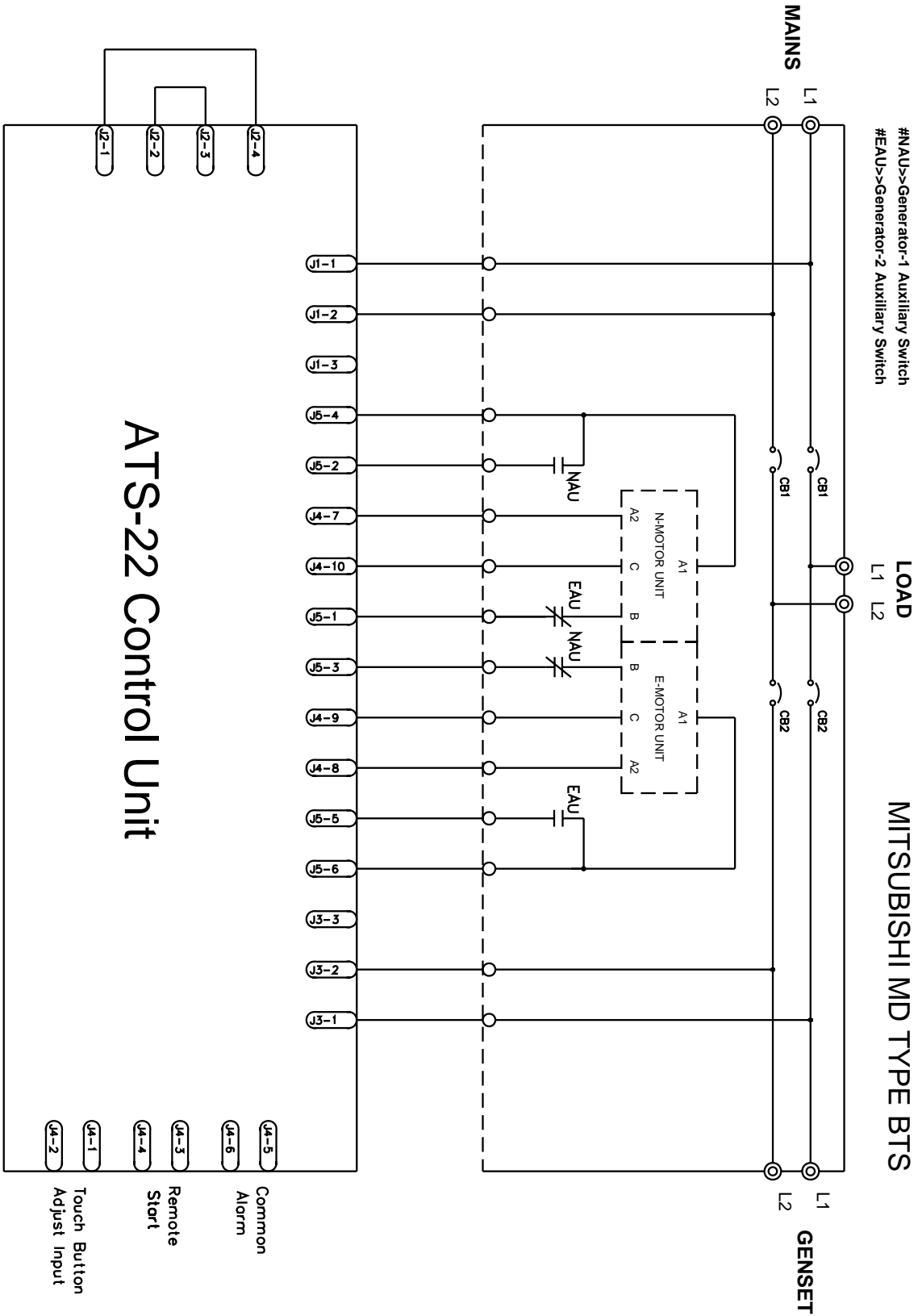

**ATS-22 AUTOMATIC TRANSFER SWITCH
CONTROL UNIT**

5.25 MERLIN GERIN MCB type ATS Wiring Diagram (3P/4P)(220VAC)

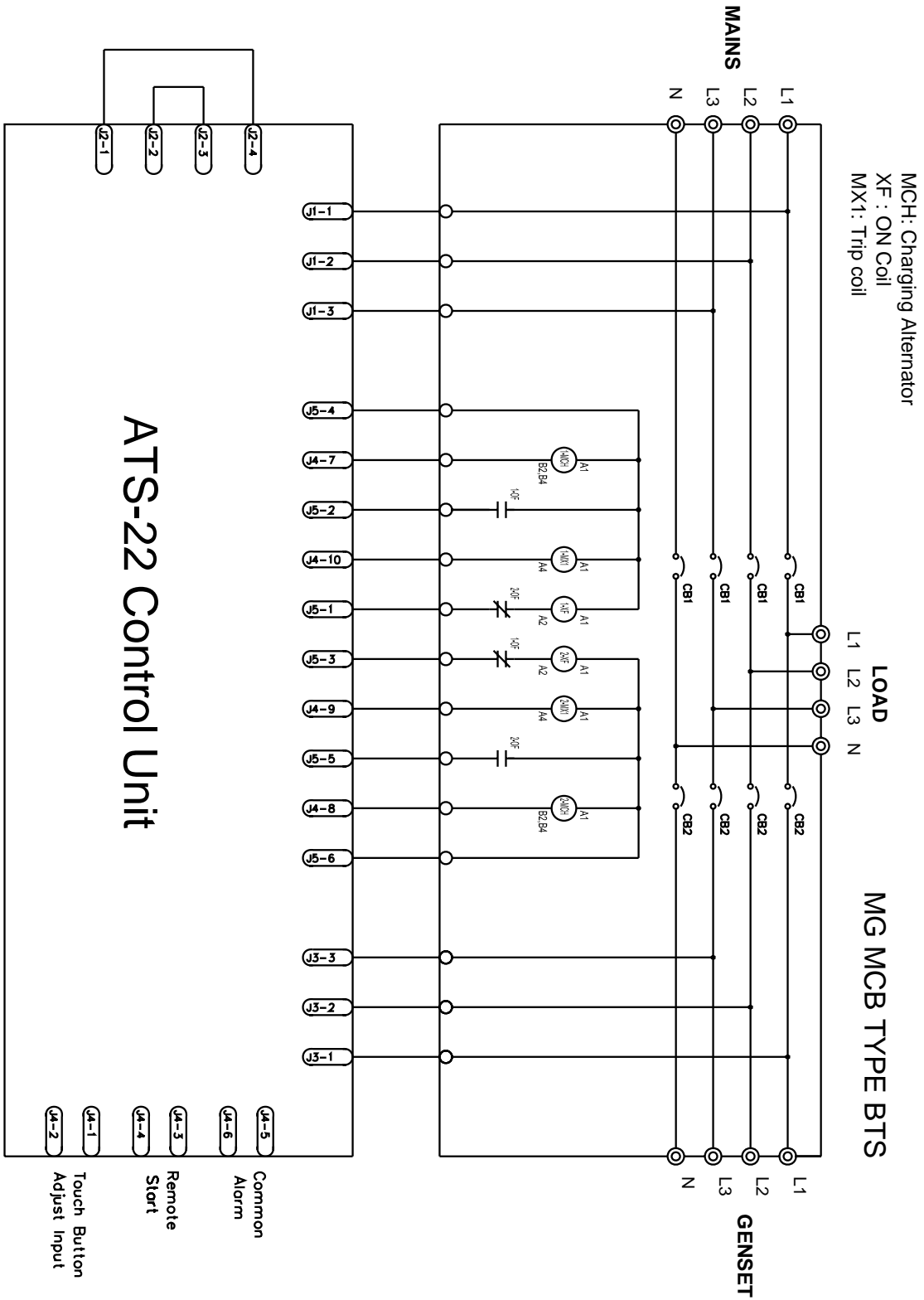

**ATS-22 AUTOMATIC TRANSFER SWITCH
CONTROL UNIT**

5.26 MERLIN GERIN MCB type ATS Wiring Diagram (2P)(220VAC)

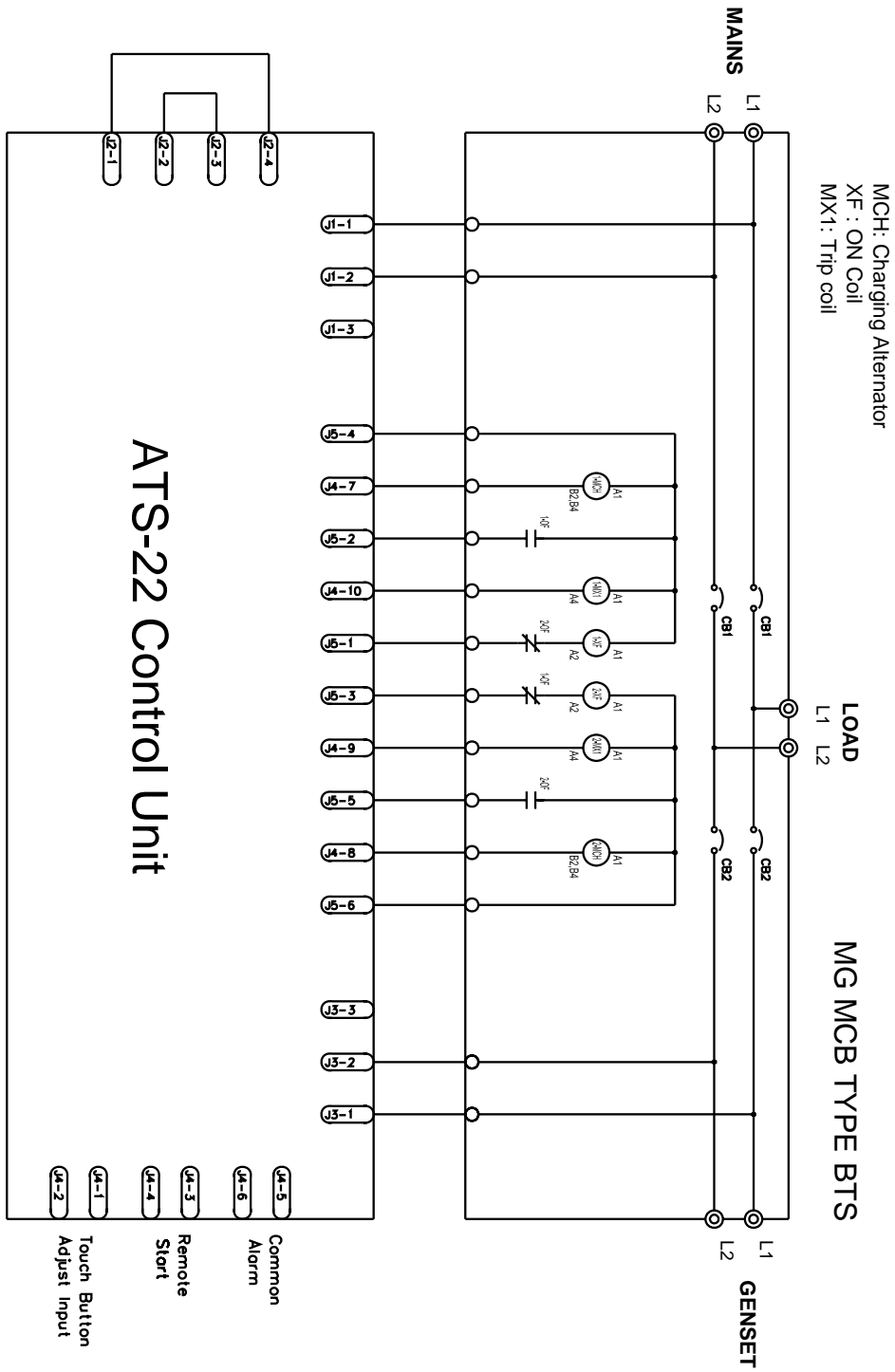

**ATS-22 AUTOMATIC TRANSFER SWITCH
CONTROL UNIT**

5.27 System Voltage different From AC220V wiring Diagram

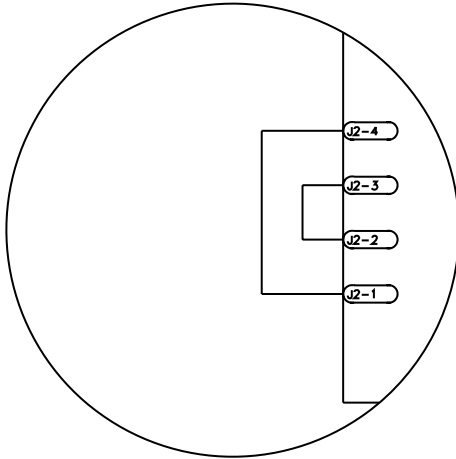

For AC220V System
with 220 V Motors controls

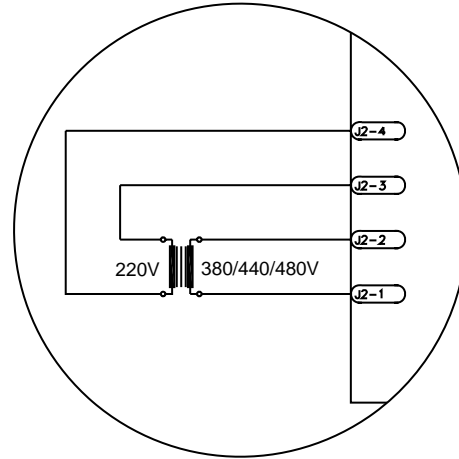

For AC380/440/480V System
with 220V motors controls

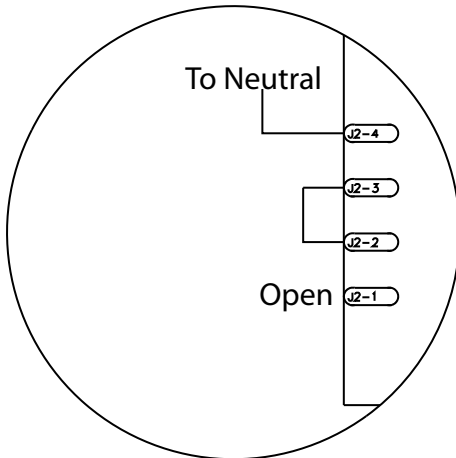

For AC110V control system

**ATS-22 AUTOMATIC TRANSFER SWITCH
CONTROL UNIT**

Note 1: Voltage Adjustment

The ATS-22 voltage readings are factory set and calibrated. However, if you need to modify any voltage reading, follow these steps.

Step 1: With grid power ON and at the same time having the generator running

Step 2: Enter Program mode and change line35 to (01). "VAdJ" will appear on the display.

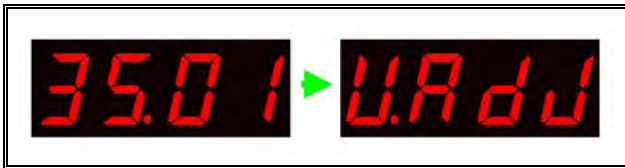

Step 3: Select the phase you wish to re-calibrate by pressing the OFF key.

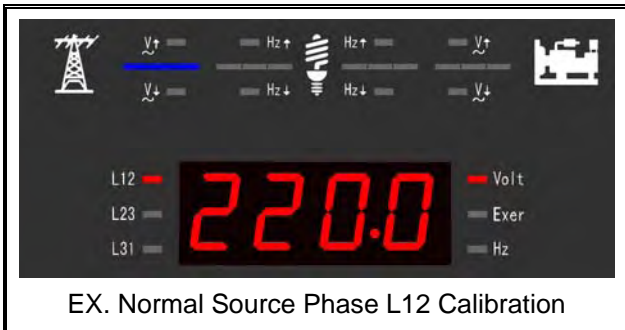

Step 4: Using a good calibrated voltmeter as your reference recalibrate the ATS-22 voltage readings.

Step 5: With the up (▲) and down (▼) buttons reset the voltage reading on the ATS-22

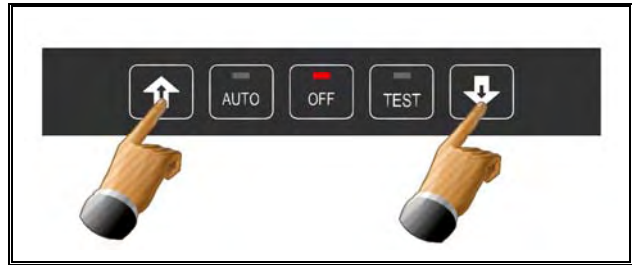

Step 6: Press the "OFF" button to move to the next phase or until the word "End" appears on the screen. To exit hold the "OFF" key at any time for 4 sec.



Step 7: If you get "FAIL", the calibration is null. Touch OFF to reset and repeat Step 1



**ATS-22 AUTOMATIC TRANSFER SWITCH
CONTROL UNIT**

Note 2: Touch Buttons Sensitivity Adjustment

The ATS-22 controller uses M-Touch capacitive touch buttons. If you need to recalibrate their sensitivity, follow these steps.

Step 1: To start short terminals J4-1 to J4-2 for 10 seconds with the ATS in any status.

Step 2: The letters “AAAA” should appear on the screen for 2 sec. confirming you can do the next steps -- touching the different buttons as instructed



Step 3: When “UP” appear on the screen, touch the (▲) key within 3 seconds, and wait for the next message to appear.



Step 4: When “AUto” appear on the screen, touch the (AUTO) key within 3 seconds, and wait for next message to appear.



Step 5: When “OFF” appear on the screen, touch the (OFF) key within 3 seconds, and then wait for next message to appear.



Step 6: When “tEst” appear on the screen, touch the

**ATS-22 AUTOMATIC TRANSFER SWITCH
CONTROL UNIT**

Step 6: When (tEst) appears, press the (TEST) key within 3 seconds, and then wait for next message to appear.



Step 7: When "don" appear on the screen, touch the (▼) key within 3 seconds, and then wait for next message to appear



Step 8: After recalibrating all five-touch buttons. The screen displays "End" for 2 seconds and exits the Touch Buttons Sensitivity Adjustment setup.



